

THIS DRAWING AND ALL INFORMATION ON IT IS THE PROPERTY OF JACOBY-TARBOX, DIVISION OF THE CLARK-RELANCE CORPORATION. IT IS CONFIDENTIAL AND IS GIVEN TO YOU FOR A LIMITED PURPOSE AND MUST BE RETURNED UPON REQUEST. NEITHER THIS DRAWING NOR ANY PART THEREOF MAY BE REPRODUCED OR TRANSMITTED IN ANY FORM OR BY ANY MEANS, ELECTRONIC OR MECHANICAL, INCLUDING PHOTOCOPYING, RECORDING, OR BY ANY INFORMATION STORAGE AND RETRIEVAL SYSTEM, WITHOUT THE WRITTEN CONSENT OF THE CLARK-RELANCE CORPORATION.

USDA DAIRY ACCEPTED

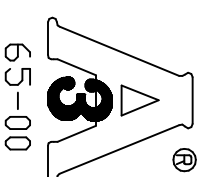
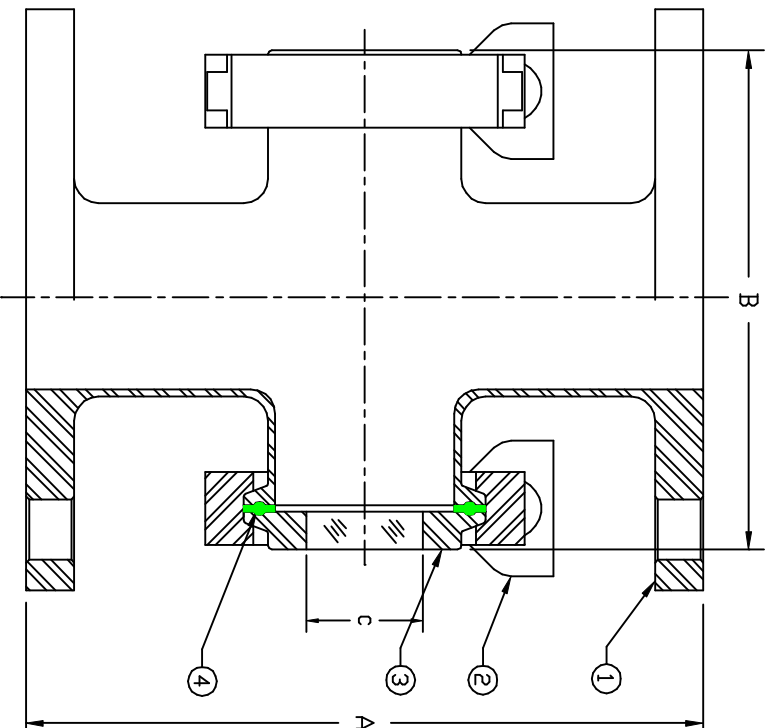

**PRESSURE/TEMP. RATINGS**

TEMP F	150 PSIG MODELS	
	304 SS	316L SS
-320 TO 100	150	150
150	150	150
200	150	150
250	150	150
300	150	150
350	150	150
400	150	150
450	150	150

SPECIAL UNIT-  
PLASTIC WINDOW  
SECTION  
ACRYLIC WINDOW  
MAX TEMP 180°F  
POLYCARBONATE WINDOW  
MAX TEMP 180°F

ITEM	NAME	QTY.	MATERIAL
1	BODY	1	
2	CLAMP	2	304 SS
3	UNI-SAN 6500	2	
4	SANITARY GASKET	2	
5	SPECIAL ACRYLIC WINDOW	1	

*SIZE	A Inches (mm)	B Inches (mm)	C Inches (mm)	D Inches (mm)	PRESSURE (MAX)
1	5.00 (127)	5.12 (130)	0.9 (23)	0.86 (22)	150 PSIG
1 1/2	5.50 (140)	5.12 (130)	0.9 (23)	1.36 (35)	150 PSIG
2	7.00 (178)	5.12 (130)	1.2 (31)	1.86 (47)	150 PSIG
2 1/2	7.00 (178)	6.00 (152)	1.5 (38)	2.36 (60)	150 PSIG
3	7.50 (191)	6.12 (155)	2.0 (51)	2.86 (73)	150 PSIG
4	9.00 (229)	7.12 (181)	3.0 (76)	3.81 (97)	150 PSIG

\* SIZES ARE STANDARD TUBE O.D.'S IN INCHES

**SPECIFICATIONS**

**Materials:**

Heads: 304 SS, 316L SS to ASTM A269

Window: UNI-SAN 6500 (Glass fused to Stainless Steel (A240,A182,A479)  
or Hastelloy-C (B574,B595) Ring.

Gaskets: Standard 3A Sanitary Gaskets

Clamps: 304 SS

**Surface Finish:**

Internal: 32 Ra (150 Grit, .8 micrometers) Standard  
(Finer finishes available upon request.)

External: 32 Ra (150 Grit, .8 micrometers) Standard