

MAXIMUM SAFETY AND STRENGTH IN SIGHT WINDOWS FOR SANITARY APPLICATIONS

Jacoby-Tarbox is industry's exclusive supplier of UNI-SAN 6500 viewing windows and TRU-SAN sight flow indicators. UNI-SAN 6500 is the result of a technologically advanced process which actually fuses glass to metal. The fusion produces a window of unmatched strength, allowing greater resistance to common causes of window failure and thereby providing today's safest window design.

All surfaces, including sealing surfaces, are finished to comply with 3-A Fittings Standards.

One-Piece Construction

The UNI-SAN 6500 component is a single unit of fused glass and metal. Competitive designs normally require, (1) lamination of multiple glass discs which become overly thick and lower

safety at higher temperatures, and (2) additional shims, packings, retainer rings or adjusting screws for proper installation. With UNI-SAN 6500, windows are homogenous, thinner and installation is easier with no undue assembly or adjustments required.

FUSION TECHNOLOGY DELIVERS UNMATCHED GLASS PROPERTIES

The UniGlas process involves heating and cooling glass inside a stainless steel ring. When the glass and metal ring are heated, fusion occurs as the ring shrinks more than the glass. In addition, high compressive stresses are created uniformly throughout the glass, resulting in unmatched resistance to failure from impact and cracking. UniGlas has been thoroughly tested to ensure the utmost in reliable performance even in conditions not normally encountered in process lines. UNI-SAN 6500 windows are of UniGlas type design.

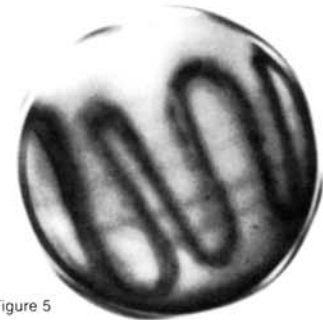

Figure 5
 BOROSILICATE GLASS STRESS PATTERN

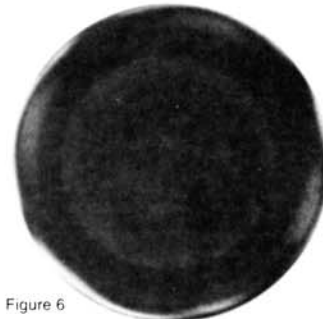

Figure 6
 UNIFORM UNIGLAS STRESS PATTERN

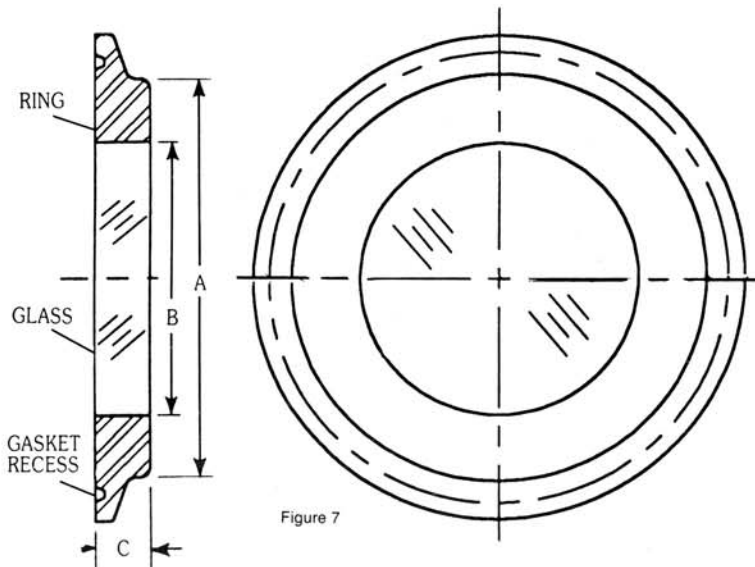

Figure 7

UNI-SAN™ 6500 WINDOWS DIMENSIONS:

Standard Tube OD (In.)	A Inches (mm)	B Inches (mm)	C Inches (mm)
1	1.60 (41)	0.90 (23)	0.75 (19)
1½	1.60 (41)	0.90 (23)	0.75 (19)
2	2.00 (51)	1.20 (30)	0.75 (19)
2½	2.50 (64)	1.50 (38)	0.75 (19)
3	3.00 (76)	2.00 (51)	0.75 (19)
4	4.00 (102)	3.00 (76)	0.75 (19)

SIZES:

For TRU-SAN 6000 Indicators

Tube OD - 1" Through 4", Standard Schedule 5 Pipe, Consult Factory
Larger Sizes, Consult Factory

For Pressure Vessel Applications

Tube OD - 1" Through 4", Standard Schedule 5 Pipe, Consult Factory
Larger Sizes, Consult Factory

MATERIALS:

Ring: Stainless Steel, ASTM A240, A479, A182, Hastelloy C (B574, B575)

Gasket: Various (See T100.45 or T100.55)

UNI-SAN™ 6500 Window Classification	Maximum Pressure	Maximum Temperature
150	150 PSIG (10.3 BAR)	600°F

UNIGLAS® TYPE WINDOWS ARE AVAILABLE ONLY FROM JACOBY-TARBOX

Jacoby-Tarbox features UNI-SAN 6500 windows as standard in sight windows and sight flow indicators used in sanitary applications as well as in other industries. A complete line of Jacoby-Tarbox products is distributed world-wide to meet routine as well as severe window and flow indicator applications.

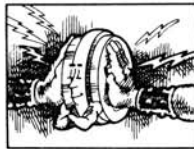

Figure 8
UNI-SAN 6500 AVOIDS FAILURES FROM UNEVEN STRESS CONCENTRATIONS THAT RESULT FROM MECHANICAL MOUNTING HARDWARE OTHER GLASS REQUIRES



Figure 9
UNI-SAN 6500 AVOIDS FAILURES FROM THERMAL SHOCK DUE TO THE INHERENT RESISTANCE VALUE OF ITS UNIFORM HIGH COMPRESSION



Figure 10
UNI-SAN 6500 AVOIDS CORROSION/EROSION FAILURES BECAUSE ITS ANNEALED SURFACES ARE MORE RESISTANT TO ATTACK

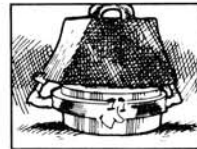

Figure 11
UNI-SAN 6500 AVOIDS FAILURES FROM MECHANICAL FORCES WITH ITS EXCEPTIONAL HIGH STRENGTH CHARACTERISTICS

HOW TO SPECIFY UNI-SAN™ 6500 WINDOWS

For Sanitary Sight Flow Indicators, New Or To Retrofit Installed Indicators

UNI-SAN 6500 windows are standard on all TRU-SAN 6000 indicator models. Refer to Catalog Section T100.45 for a complete presentation on model choices and model specification information.

For Sight Windows In Vessel Applications, New Or To Retrofit Existing Vessel Windows

UNI-SAN 6500 sight windows for vessel applications can be specified by contacting your local Jacoby-Tarbox representative or by contacting the factory direct.



NOTE: Jacoby-Tarbox shall not be liable for damages of any kind resulting in part from failure to install its products in accordance with all applicable codes and/or state and local regulations, improper application and/or maintenance.



JACOBY-TARBOX®

A Product Line of The Clark•Reliance® Corporation
16633 Foltz Industrial Parkway, Strongsville, OH 44149 USA
Telephone: (440) 572-1500 Fax: (440) 238-8828

