

SG677 VALVE REPAIR INSTRUCTIONS

A. Disassembly of Stop Valves for Inspection and Repair

Caution: Before any attempt is made to disassemble the valve, verify that the valve is isolated from system pressure and secured against accidental pressurization. Follow standard tag out safety procedures before proceeding.

NOTE: VALVE WITH SIZE CODE 8, 9, 10 HAVE HANDLE & ADAPTOR (IMPACTOR HANDLE)

FIGURE B

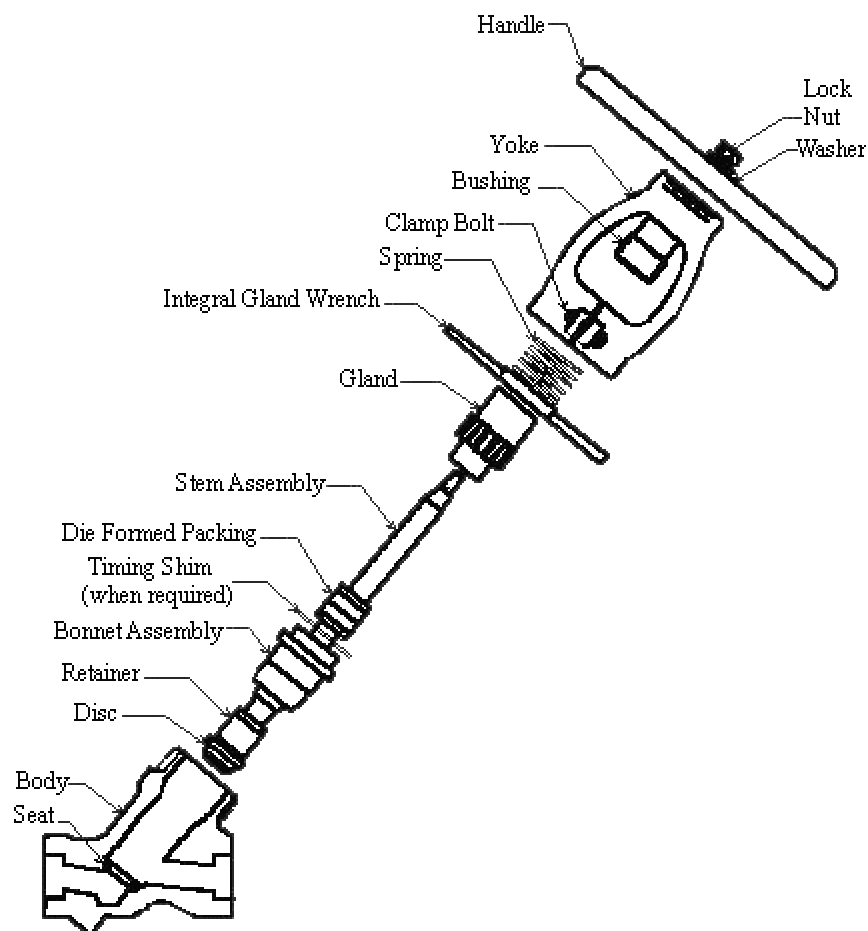

1. Completely remove the clampbolt from the yoke and screw it into the opposite (threaded) side of the clampbolt lug. Place a metal flat (like a fender washer) into the yoke split to stop the clampbolt. Tighten clampbolt, using it as a jacking

- screw, until the yoke split expands by 1/16" (this is to relieve yoke thread friction).
2. Unscrew the yoke, using a Conval Yoke Wrench. Remove the yoke assembly carefully so that the stem and disc do not scratch the bonnet sealing surface. If the bonnet becomes stuck in the body, proceed with steps 3-5 and use a small wedge under the bonnet flange.
 3. Remove lock nut, washer, and valve handle.
 4. Removal of the stem from the yoke assembly requires threading the stem down through the yoke bushing. To make removal easier it is helpful to clean the stem threads thoroughly with a wire brush and solvent. Some filing may also be required to clean the threads at the handle flats.
 5. Remove timing shims (if supplied) from bonnet. Shims are provided in some valves to maintain proper yoke orientation. Keep the original shim set with the valve for reassembly.
 6. To remove bonnet, invert stem and press bonnet down over stem.
 7. Inspect the condition of the sealing surfaces for damage:
 - * Body Seat, Bonnet seal
 - * Stem Disc sealing surface, packing sealing surface, backseat lip of retainer
 - * Bonnet Backseat nose, body seal, packing chamber surface

B. REPACKING

1. Remove old packing using a soft dowel (wood, plastic or brass). Put bonnet on table upside down and press rings out from the bottom. It's helpful to soak the bonnet and packing in solvent to loosen packing before removal.

WARNING: Do not use a standard packing puller. It will cause scoring of the bonnet chamber and create a leak path.

FIGURE C

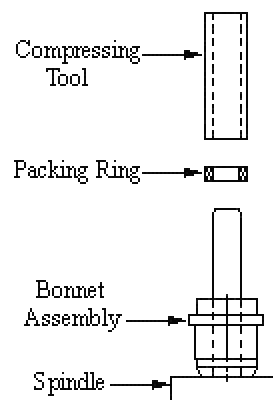

- Clean bonnet chamber in clean solvent to remove contaminants which will contribute to stem pitting. Place the bonnet chamber over the spindle of the Conval repacking tool, adding rings individually and manually depress them into the chamber with the compressing sleeve. No preloading is required. The order of assembly is as shown in Figure C (above).

NOTE: Use only die formed graphitic seal rings and woven graphitic wiper rings for best packing performance. See below for correct size.

Repacking Tool	Size Code	Packing Rings		Wiper Rings	
		OD x ID x HT	Qty	OD x ID x HT	Qty
T3-RP-1	3C 3D 5C 5D	3/4 x 1/2 x 1/4	2	3/4 x 1/2 x 1/8	2
T5-RP-1	5E 5F 5G 6E 6G 6H 7E	1 x 5/8 x 3/8	2	1 x 5/8 x 3/16	2
T7-RP-1	7F 7G 7H 7J 8F	1-1/4 x 3/4 x 1/2	2	1-1/4 x 3/4 x 1/4	2
T8-RP-1	8G 8H 8J 8K 9G 9H 10H	1-3/8 x 7/8 x 1/2	2	1-3/8 x 7/8 x 1/4	2
T9-RP-1	9J 9K 9L 10J	1-3/4 x 1-1/8 x 3/8	3	1-3/4 x 1-1/8 x 5/16	2
T10-RP-1	10K 10L 10M	1-7/8 x 1-1/4 x 5/8	2	1-7/8 x 1-1/4 x 5/16	2

C. SEAT REFACING

- Disassemble valve.
- Taking the seat refacing tool in hand, screw both halves of the sleeve assembly together clockwise until they bottom out against each other. The sleeve assembly is now at it's shortest length.
- Unscrew feed lever from housing assembly and then screw in one complete turn.
- Carefully insert refacing tool into body cavity. Prevent damage to bonnet sealing surface.
- Screw yoke collar onto body threads and hand tighten.
- Press down on shaft to insure cutting head is resting against seat.
- Pull up on shaft until sleeve assembly restricts upward movement. Determine, approximately, the amount of "play" between the full-up and full-down position. Play should be approximately 1/16". The adjustable sleeve must be long enough so that the feed collar is doing the work of pressing the cutter into the

seat, but not long that the housing is not firmly inserted into the valve body. If this is not occurring, remove the refacing tool and readjust the sleeve until proper fit is achieved.

8. **DO NOT FEED CUTTER WITHOUT ROTATING SHAFT.** Attach socket wrench to hex nut at the top of the shaft and begin to rotate shaft in clockwise direction. While rotating shaft, turn feed lever clockwise until cutter begins to cut. Continue to rotate shaft while turning feed lever clockwise, insuring continuous cutting. Note position of feed lever when cutting starts to occur. Cut no more than one-quarter turn of feed lever.
9. Clear body of chips with solvent and a rag.

FIGURE D

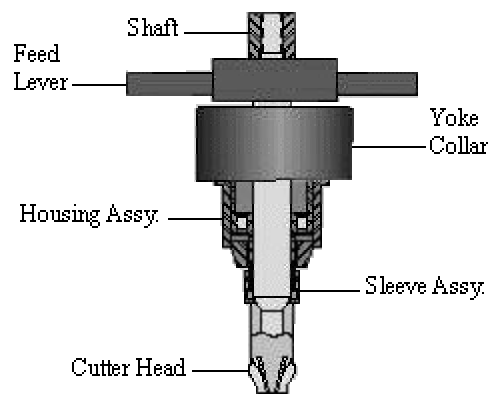

SEAT REFACING TOOL

(Note: [Click here for Seat Refacing Tool part numbers](#))

D. DISC REFACING

Chuck the retainer portion of the stem assembly in a lathe and center to within .001". Use a single point carbide tool (Kennametal Grade K68 or equal) with a fine feed and cutting speed of 30-50 S.F.P.M. Machine the minimum amount of metal necessary to clean the surface to $29^{\circ} \pm 10$ min.

E. BONNET SEAT REFACING

1. Assemble Bonnet Lapping Tool as shown in Figure E (below).
2. Apply a small amount of Lapping Compound to the seating surface of the Bonnet Lapping Tool. Use compound 120 (coarse) for rough lapping, 280 (fine) for final lapping.
3. Apply slight downward pressure on the Bonnet Lapping Tool. Lap back and forth until a smooth finish on the Bonnet lip is achieved.
4. Clean parts thoroughly with solvent and a clean rag.

FIGURE E

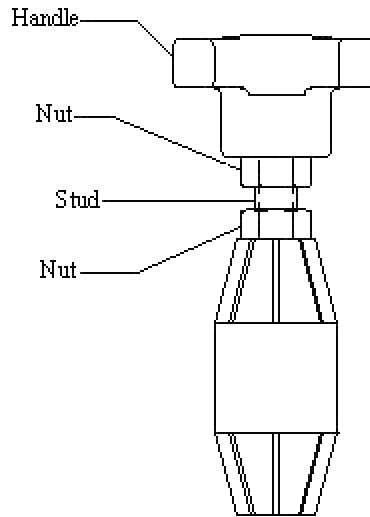

BONNET LAPPING TOOL

(Note: [Click here for Bonnet Lapping Tool part numbers](#))

F. SEAT LAPPING

1. Assemble lapping tool as shown in figure F (below).
2. Sleeve should be loose so that the disc can wobble easily. Secure sleeve in this position by tightening the hex nut.
3. Apply a small amount of lapping compound to the seating surface of the disc. Use compound 120 (coarse) for rough lapping, 280 (fine) for final lapping.
4. Maintain slight downward pressure on the stem. Lap back and forth for about two minutes or until a smooth finish on the disc and seat is achieved.
Note: Overlapping will result in full face contact between seat and disc. The goal is to maintain a 1/16" line contact.
5. Clean parts thoroughly with solvent and a clean rag.

FIGURE F

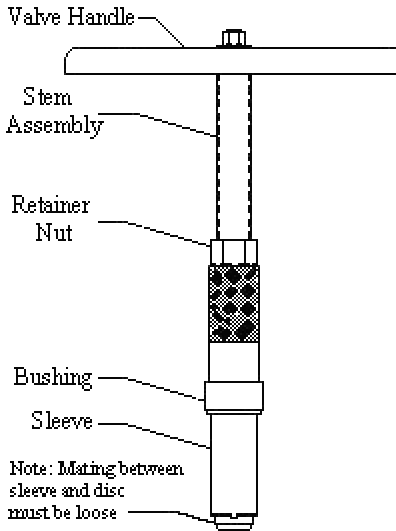

STOP VALVE LAPPING TOOL

(Note: [Click here for Stop Valve Lapping Tool Part Numbers](#))

G. REASSEMBLY

1. Clean all parts thoroughly with cleaning solvent.
2. Coat body/yoke threads with a nickel anti-seize lubricant.
3. Assemble the components in the following order:
 - a. Use repacking tool sleeve to hold packing inside of the bonnet chamber as bonnet is slid onto stem assembly.
 - b. Screw packing gland to its highest point on the yoke bushing.
 - c. Replace timing shims (if shims were provided originally) onto bonnet chamber and screw stem assembly into yoke to mid travel position. Keep timing shims flat on bonnet ledge.
 - d. Use clambolt to spread yoke as described in [Step 1 of the repair section above](#). Place yoke assembly into body. Avoid contact between disc and body/bonnet seal surfaces as the yoke assembly is placed into the body.
 - e. Screw yoke onto body. Insure that stem is in mid travel and gland is at top of yoke bushing. Apply torque as specified in [Table 2](#). **DO NOT OVER TORQUE!**
 - f. If yoke alignment must be changed add .030" thick shims for each 90° of desired rotation.
 - g. Return clambolt to normal position and tighten per [Table 2](#).
 - h. Place handle and fasteners onto stem and tighten.
 - i. Cycle valve several times to seat packing and readjust packing gland. Tighten packing gland per Table 3 (below).

TABLE 3
SEI-26 OPERATING GLAND TORQUES (FT-LBS)

	ANSI PRESSURE CLASS									
SIZE CODE	600	900	1195	1500	2155	2500	3045	3500	4095	4500
3C	4	4	4	4	4	4	5	-	-	-
3D	4	4	4	4	4	-	-	-	-	-
5C	4	4	4	4	4	4	5	6	7	8
5D	4	4	4	4	4	4	5	6	7	-
5E	8	8	8	8	9	10	12	-	-	-
5F	8	8	8	8	9	-	-	-	-	-
5G	8	8	8	-	-	-	-	-	-	-
6E	8	8	8	8	9	10	12	14	17	18
6G	8	8	8	8	9	-	-	-	-	-
6H	8	8	8	-	-	-	-	-	-	-
7E	8	8	8	8	9	10	12	14	17	18
7F	15	15	15	15	16	19	23	26	30	33
7G	15	15	15	15	16	19	23	-	-	-
7H	15	15	15	15	16	-	-	-	-	-
7J	15	15	15	-	-	-	-	-	-	-
8F	15	15	15	15	16	19	23	26	30	33
8G	18	18	18	18	20	23	28	32	37	-
8H	18	18	18	18	20	23	28	-	-	-
8J	18	18	18	18	20	-	-	-	-	-
8K	18	18	18	-	-	-	-	-	-	-
9G	18	18	18	18	20	23	28	32	37	41

9H	18	18	18	18	20	23	28	32	37	-
9J	37	37	37	37	40	46	56	-	-	-
9K	37	37	37	37	40	-	-	-	-	-
9L	37	37	37	-	-	-	-	-	-	-
10H	18	18	18	18	20	23	28	32	37	41
10J	37	37	37	37	40	40	56	64	75	-
10K	47	47	47	47	50	50	71	-	-	-
10L	47	47	47	47	50	-	-	-	-	-
10M	47	47	47	-	-	-	-	-	-	-

MAINTENANCE

All components of the CLAMPSEAL® valve are shown and named in Figure B. CLAMPSEAL® valves have several distinctly different design features from other valves. These servicing instructions should be followed closely.

Routine Maintenance

Routine maintenance consists of a periodic tightening of the gland to prevent packing leakage. Graphite packing manufacturers recommend routine replacement of packing after 3 years of service. No other routine maintenance is required.

Adding a Ring of Packing Under Pressure

Packing will eventually wear to the point where tightening of the gland will not affect a seal. When this happens it is possible to add a packing ring under pressure as follows:

Note: This is only a temporary solution until the valve can be disassembled and repacked.

1. Isolate the valve and allow pressure to bleed off. Tag-out isolation valves. Follow prescribed safety procedures for your plant.
When the valve is pressurized, the valve backseat provides pressure enhanced positive sealing. This feature does not provide a two valve protection which is specified in some safety standards. Proceed only as a last resort. Do not try to remove packing from a pressurized valve.
2. Open the valve fully and torque onto backseat. See [Table 2](#) for torque. Over torquing will not enhance the seal and could cause damage.
3. Wait for leakage to stop as the fluid or gas trapped in the packing blows down.
CAUTION: IF LEAKAGE PERSISTS DO NOT PROCEED!
4. Remove handle to prevent accidental movement off of backseat.
5. Use gland wrench ([Figure A.](#)) to slowly screw the gland to full height on the yoke bushing, while checking for blow by.
6. Open new graphite filament wiper packing ring at split for insertion around the stem.
7. Slide ring into bonnet chamber and compress by tightening the gland. Loosen the gland to see if another ring will fit. If so, rotate second ring split one-quarter turn from first ring.
8. Tighten gland. Do not exceed torque listed in table 3. Rotate stem several times, in both directions, to seat packing.

TABLE 2
OPERATING TORQUES (FT-LBS)

SIZE CODE	YOKE	SEATING	BACKSEAT	CLAMPBOLT
3C 3D	100	30	4	15
5C 5D	150	30	4	15
5E 5F 5G	150	60	6	15
6E 6F 6G 6H	200	60	6	15
7E	250	60	6	25
7F 7G 7H 7J	250	100	9	25
8F	350	100	9	25
8G 8H 8J 8K	350	230	12	25
9G 9H	425	230	12	60
9J 9K 9L	425	420	18	60
10H	600	230	12	105
10J	600	420	18	105
10K 10L 10M	600	500	25	105



Notice to Plant Operators

The use of non-Original Equipment Manufacturer parts (such as glass, gaskets, probes, modules, etc.) will void the Agency Approval (FM, UL, CSA, CRN, ABS, etc.), pressure/temperature rating, and warranty of this equipment. Clark-Reliance requires the use of OEM parts for all repairs on this product in order to maintain plant and personnel safety, and reliable operation.

"PARTS-PLUS"
Critical spare parts for overnight
delivery, direct from the manufacturer.

clark-reliance.com/parts



Steel Valve Repair Kit



Replacement Probes



Gage Glass Repair Kit



Simpliport Module



Simpliport Packing Nut



Replacement Relays

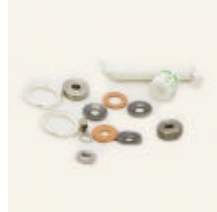

Probe Repair Kit



Replacement EA100 Ass'y



Replacement Micro-switch



Bronze Valve Repair Kit



Valve Packing



Replacement Floats

16633 Foltz Parkway Strongsville, OH 44149 USA
Phone (440) 572-1500 Fax (440) 238-8828
sales@clark-reliance.com www.clark-reliance.com