

BILL OF MATERIAL

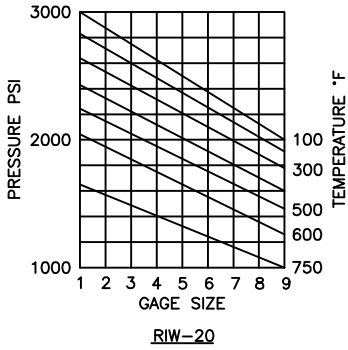

| PIECE NO. | NAME OF PART | NO. REQ'D FOR ASMBLY | | | | MATERIAL | MATERIAL SPECIFICATION | PART NO. | MATERIAL | MATERIAL SPECIFICATION |
|-----------|--------------|----------------------|---|---|---|-----------|------------------------|-----------------------------|-------------|------------------------|
| | | A | R | N | T | | | | | |
| 1 | CHAMBER | 1 | | | | STEEL | AISI C-1018 | S-9476-A1 | | |
| 2 | CHAMBER | | 1 | | | 304 SS | QQ-S-763/766 COND.A | S-9476-R2 | | |
| 3 | CHAMBER | | | 1 | | MONEL | QQ-N-281 CL.A | S-9476-N | | |
| 4 | COVER | ONE PER SECTION | | | | STEEL | AISI C-1040 | V-2- -A4 | | |
| 5 | GLASS | | | | | TEMPERED | | V-16757- | | |
| 6 | GASKET | * | | | | IFG5500 | | V-18980- | | |
| 7 | GASKET | * | * | * | * | IFG5500 | | V-18980- | | |
| 8 | BOLTS | SEE CHART | | | | STEEL | ASTM A193 | P-4527-B71 | | |
| 9 | STEM NUT | 2 | 2 | 2 | 2 | STEEL | PLATED | S-9055 ASSEMBLY 'R'/'N'/'T' | STEEL | PLATED |
| 10 | HANDWHEEL | 2 | 2 | 2 | 2 | MAL. IRON | ASTM A47 | | MAL. IRON | ASTM A47 |
| 11 | STEM | 2 | 2 | 2 | 2 | 416 SS | ASTM A276 | | 316 SS | AISI TP 316 |
| 12 | PACKING NUT | 2 | 2 | 2 | 2 | STEEL | ASTM A108 | 316 SS | AISI TP 316 | |
| 13 | GLAND | 2 | 2 | 2 | 2 | STEEL | ASTM A108 | 316 SS | AISI TP 316 | |
| 14 | BONNET | 2 | 2 | 2 | 2 | STEEL | ASTM A108 | 316 SS | AISI TP 316 | |
| 15 | PACKING | 2 | 2 | 2 | 2 | GPH/NICR | COMM'L | TEFLON | COMM'L | |
| 16 | CHAMBER | | | | 1 | 316L SS | QQS-763/766 COND. A | S-9476-TL2 | | |

+ SPECIFY GAGE * TWO PER SECTION

| SIZE NO. | BOLTS PER SECT. | DIM. 'B' IN INCHES | NUMBER OF SECTIONS | | | | | | | | | |
|----------|-----------------|--------------------|-------------------------|--------|--------|--------|--------|--------|---------|---------|---------|--|
| | | | DIMENSION 'A' IN INCHES | | | | | | | | | |
| | | | 1 | 2 | 3 | 4 | 5 | 6 | 7 | 8 | 9 | |
| 1 | 6 | 3-3/4 | 8-3/4 | 14 | 19-1/4 | 24-1/2 | 29-3/4 | 35 | 40-1/4 | 45-1/2 | 50-3/4 | |
| 2 | 6 | 4-3/4 | 9-3/4 | 16 | 22-1/4 | 28-1/2 | 34-3/4 | 41 | 47-1/4 | 53-1/2 | 59-3/4 | |
| 3 | 8 | 5-3/4 | 10-3/4 | 18 | 25-1/4 | 32-1/2 | 39-3/4 | 47 | 54-1/4 | 61-1/2 | 68-3/4 | |
| 4 | 10 | 6-3/4 | 11-3/4 | 20 | 28-1/4 | 36-1/2 | 44-3/4 | 53 | 61-1/4 | 69-1/2 | 77-3/4 | |
| 5 | 10 | 7-7/8 | 12-7/8 | 22-1/4 | 31-5/8 | 41 | 50-3/8 | 59-3/4 | 69-1/8 | 78-1/2 | 87-7/8 | |
| 6 | 12 | 9-1/8 | 14-1/8 | 24-3/4 | 35-3/8 | 46 | 56-5/8 | 67-1/4 | 77-7/8 | 88-1/2 | 99-1/8 | |
| 7 | 14 | 10-1/4 | 15-1/4 | 27 | 38-3/4 | 50-1/2 | 62-1/4 | 74 | 85-3/4 | 97-1/2 | 109-1/4 | |
| 8 | 16 | 11-7/8 | 16-7/8 | 30-1/4 | 43-5/8 | 57 | 70-3/8 | 83-3/4 | 97-1/8 | 110-1/2 | 123-7/8 | |
| 9 | 18 | 12-5/8 | 17-5/8 | 31-3/4 | 45-7/8 | 60 | 74-1/8 | 88-1/4 | 102-3/8 | 116-1/2 | 130-5/8 | |

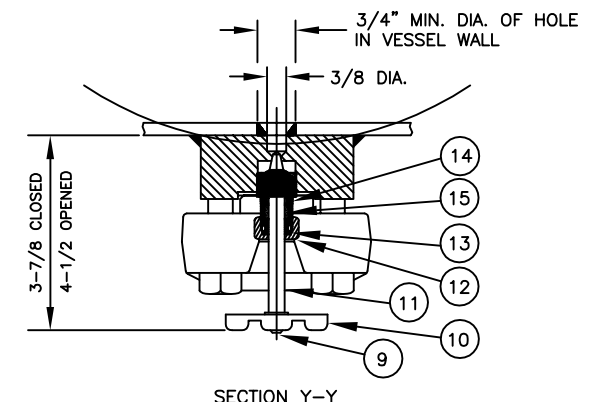
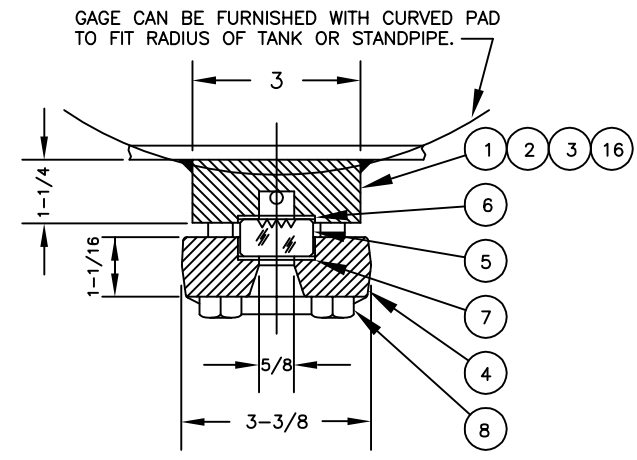
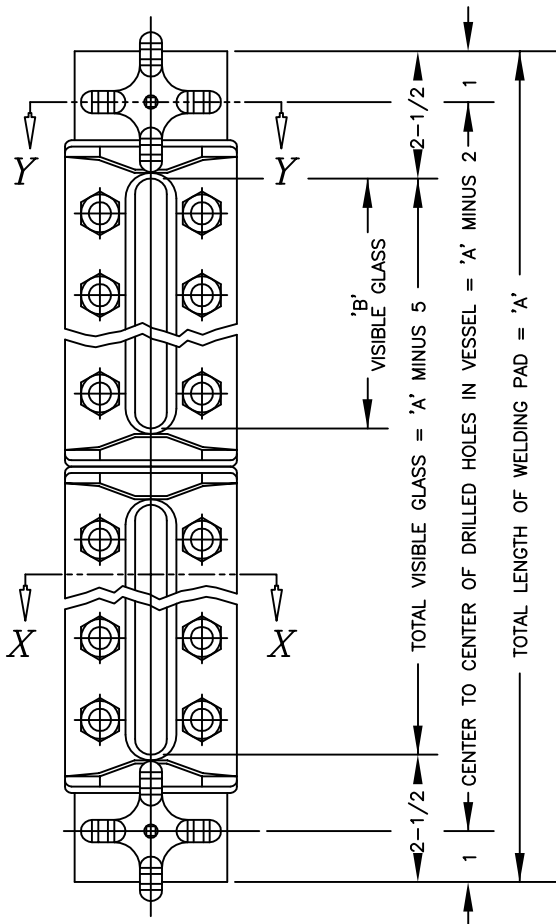

| | | | |
|-----|---------------------|---------|-----|
| 6 | ADDED RATINGS CHART | 6/1/98 | |
| 5 | REDRAWN | 7/19/96 | |
| SYM | REVISION | DATE | APP |

ISOLABLE RIW-20
WELDING PAD GAGES

JERGUSON
GAGE & VALVE CO.
STRONGSVILLE, OHIO, U.S.A.

SCALE NONE DATE 6/1/98

| | | | |
|----------|-----|-------------|----------|
| DRAWN | LMC | FILE NO. | |
| CHECKED | MJK | DRAWING NO. | R20-IW00 |
| APPROVED | | REV. | 6 |