

### Coalescer Filter PiW 1975

#### 1. Description

The Coalescer filter has been specially designed to separate water from hydraulic fluids.

According to VDMA standard sheet 24568, the amount of water in HE pressure fluids has to be kept below 1000 ppm (0.1 %). HLP fluids should not contain any free water at all. Free water always causes turbidity which can be seen by the human eye. Physically, turbidity is a two-phase mixture (emulsion) in which small droplets of water are present in the pressure fluid. For this reason, it is advisable to carry out a mechanical separation of these water droplets; this technique is based on the coalescer - principle. The droplets are collected in various layers and brought together into larger units. The water drops thus formed are several millimetres in diameter.

After leaving the coalescer layer, the drops come in contact with a special hydrophobic fabric, where the separation from the pressure fluid takes place. The water is removed from the cycle by means of sedimentation. It is important that a certain differential pressure is not exceeded during the process. The viscosity also needs to be taken into account to ensure proper operation. The maximum viscosity for effective water separation is approx. 68 mm<sup>2</sup>/s. The coalescer works best if the pressure fluids contain a minimal amount of emulsive additives. The bottom line: in systems that are frequently at risk for water ingress, expensive special oils can be replaced by simple, cost-effective pressure fluids.

#### Characteristics

- Mechanical separation of water droplets - coalescer principle
- Water removing by means of sedimentation
- Expensive special oils can be replaced by simple, cost-effective pressure fluids

#### Worldwide distribution



## 2. Flow rate

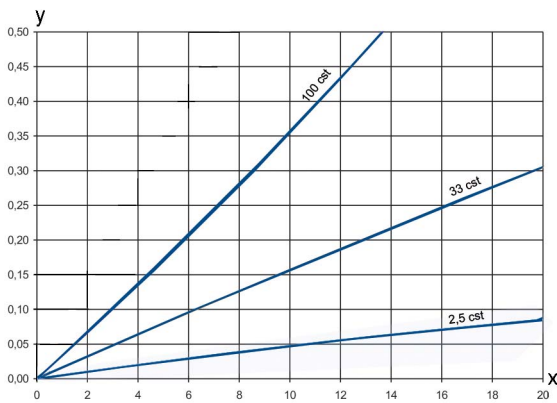

y = differential pressure in bar  
x = flow rate in l/min

## 3. Water solubility

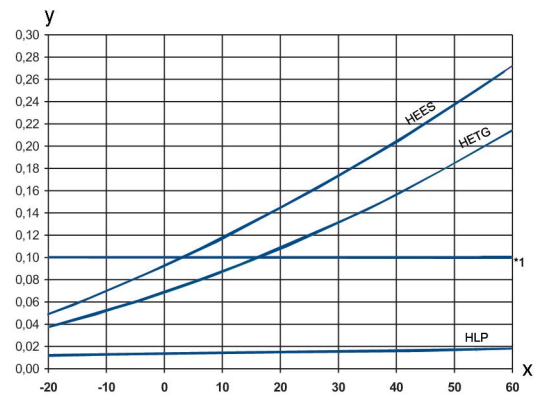

1\* VDMA-threshold

## 4. Quality assurance

MAHLE filter and filter elements are manufactured respectively, tested in accordance with the following international standards:

Norm	Designation
DIN ISO 2941	Hydraulic fluid power filter elements; verification of collapse/burst resistance
DIN ISO 2942	Hydraulic fluid power filter elements; verification of fabrication integrity
DIN ISO 2943	Hydraulic fluid power filter elements; verification of material compatibility with fluids
DIN ISO 2923	Hydraulic fluid power filter elements; method for end load test
DIN ISO 2924	Hydraulic fluid power filter elements; verification of flow fatigue characteristics
ISO 3968	Hydraulic fluid power filters; evaluation of pressure drop versus flow characteristics
ISO 10771.1	Fatigue pressure testing of metal containing envelopes in hydraulic fluid applications
ISO 16889	Hydraulic fluid power filters; multipass method for evaluation filtration performance of a filter element

## 5. Symbols

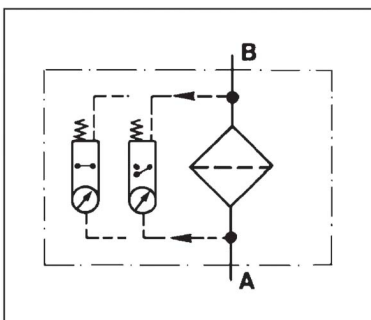

## 6. Order number

Housing Design	Spare parts
complete with optical/electrical indicator, demister and coalescer element Type: PiW 1975/E-Coalescer Order number: 76334031	Type: 853 275 Coalescer Order number: 76345300

## 7. Specification

Design:	line mounting filter
Operating pressure:	6 bar
Test pressure:	8 bar
Temperature range:	-10 °C to +80 °C (other temperature ranges on request)
Filter housing material:	St
Sealing material:	NBR/Cu
Activating pressure of optical/electrical differential pressure indicator:	$\Delta p$ 1.2 bar $\pm$ 0.2 bar
Electrical data of contamination indicator:	
Maximum voltage:	250 V AC/200 V DC
Maximum current on contact:	1 A
Inrush current:	70 W
Type of protection:	IP 65 when inserted and secured
Contact:	bistable
Cable connection:	M 20 x 1.5

The switching function can be changed by turning the electric upper part by 180° (normally closed contact or normally open contact). The state on delivery is a normally closed contact.

The use of quenching circuits must be checked in the case of inductivity in the DC current circuit. The contamination indicator data sheet contains further information and additional contamination indicator versions.

We draw attention to the fact that all values indicated are average values which do not always occur in specific cases of application. Our products are continually being further developed. Values, dimensions and weights can change as a result of this. Our specialized department will be pleased to offer you advice.

When using our filters in areas which are to be classified according to EU Directive 94/9 EC (ATEX 95), we recommend prior discussion with us. The standard version can be used for liquids based on mineral oil (corresponding to the fluids in Group 2 of Directive 97/23 EC Article 9). Please consult with us if using other media.

Subject to technical alteration without prior notice.

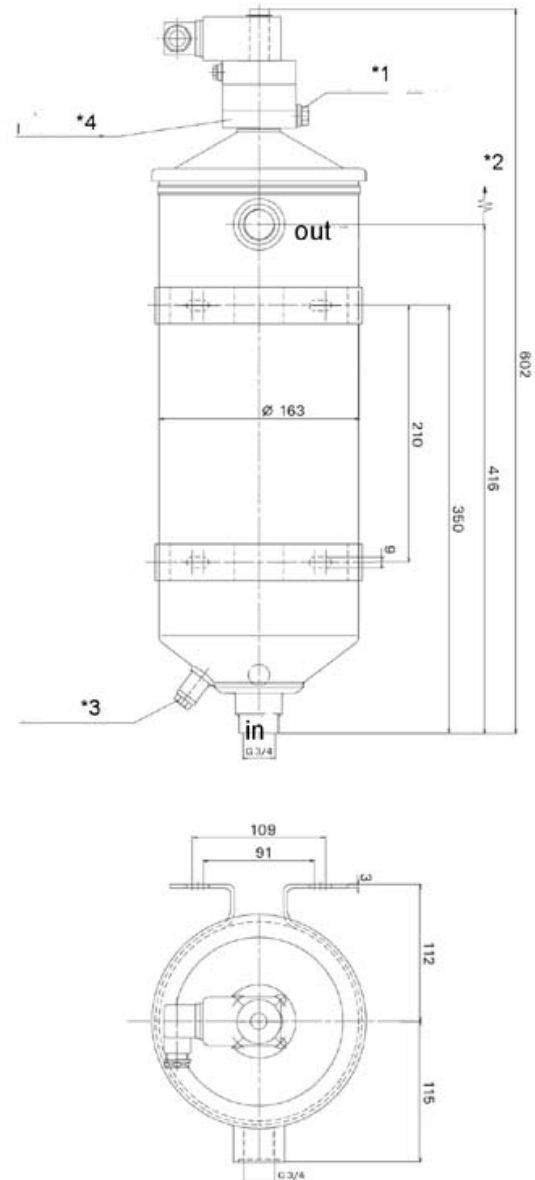

weight 8 kg

- \*1 vent screw
- \*2 extension degree 400
- \*3 drain screw G 1/2 drawn 90° shifted
- \*4 SW 36/ for filter maintenance

## 8. Installation, operating and maintenance instructions

### 8.1 Filter installation

When installing filter make sure that sufficient space is available to remove filter element.

Install filter vertical so that the secluded water can flow down and can be discharged.

### 8.2 Connecting the electrical contamination indicator

The electrical indicator is connected via a 2-pole appliance plug according to DIN EN 175301-803, with poles marked 1 and 2. The electrical section can be inverted to change from normally open to normally closed position and vice versa.

### 8.3 Operating instruction

The max. viscosity for an effective water separation should not exceed 68 mm<sup>2</sup>/s. The coalescer should run with a differential pressure of approx. 0.3 bar, that means that the volumetric flow is determined by the viscosity of the oil. To prevent premature contamination of the coalescer, a dirt filter with a retention rate of  $\beta_6 \geq 75$  should be installed before the coalescer, because the coalescer element is so fine and therefore very sensitive to dirt. In order to recognise the separated water, a transparent water-detection device with a tap should be mounted to the cone of the filter housing.

### 8.4 When does the coalescer element need to be replaced?

A differential pressure indicator with a switching point of  $\Delta p$  1.2 bar is mounted at the top of the filter housing. As already mentioned above, the filter should run at  $\Delta p$  of approx. 0.3 bar. If the indicator signals in the "correct" conditions, the coalescer element is contaminated and needs to be replaced.

### 8.5 Replacing the coalescer element

Before an element can be replaced, the entire system needs to be shut down and the filter released from the pressure. Use the water tap to empty the housing. The differential indicator (1) also serves as a cover screw which needs to be removed to take off the cover (2). Remove the coalescer element (3) from the housing. The demister only needs to be replaced, if it is damaged.

Push a new coalescer element over the centre pipe in the housing.

Check seals in the lid-cover for possible damages, replace if necessary.

Place the lid-cover back on top of the housing and tighten it with the differential pressure indicator.

Close the water tap.

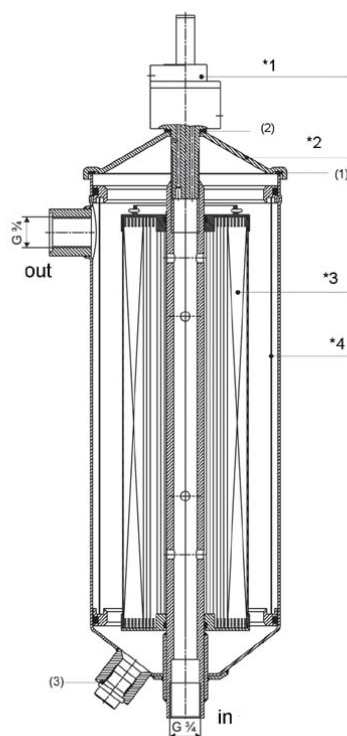

- \*1 differential pressure indicator (4)
- \*2 cover (5)
- \*3 coalescer element (6)
- \*4 demister (7)
- \*5 water tap G 1/2

## 9. Spare parts list

Order numbers for spare parts		
Position	Type	Order number
①	Seal kit for housing	76375364
	NBR	
④	Contamination indicator	76375372
	Optisch PiS 3111/1.2	
	Electrical PiS 3114/1.2	
	Seal kit for contamination indicator	78389280
	NBR	
⑦	Demister	76375398

MAHLE Filtersysteme GmbH  
 Industriefiltration  
 Schleifbachweg 45  
 D-74613 Öhringen  
 Phone +49 (0) 7941/67-0  
 Fax +49 (0) 7941/67-23429  
 industriefiltration@mahle.com  
 www.mahle-industriefiltration.com  
 76349864.11/2006