

Duplex Filter

Pi 370

Operating pressure 200 (250) bar, Nominal size up to 450

1. Features

Efficient filters for modern hydraulic systems

- Modular design principle
- Compact design
- Minimal pressure drop
- Optical/electrical/electronic contamination control
- Threaded or SAE 4 bolt flange ports
- Switching valve on upstream side
- Ergonomic switch-over handle with safety lock and pressure compensation
- User-optimized one-hand-operation

Quality filters, easy to service

- Equipped with highly efficient SM-x filter elements
- β -valued elements per ISO 16889
- High dirt holding capacity and differential pressure stability providing optimal element service life

Worldwide distribution



2. Flow rate/pressure drop curve complete filter

190 mm²/s (25° E)
33 mm²/s (4,5° E)

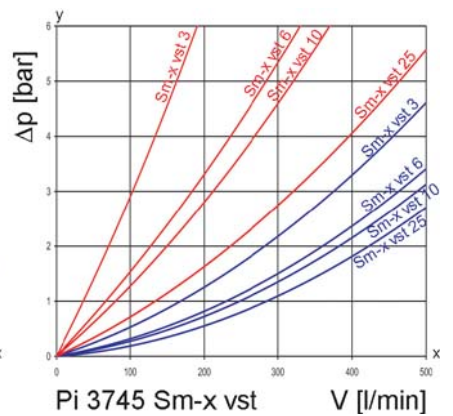
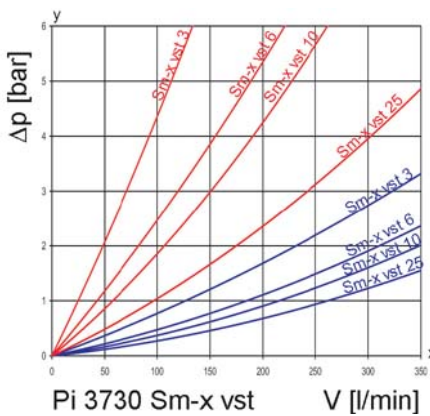
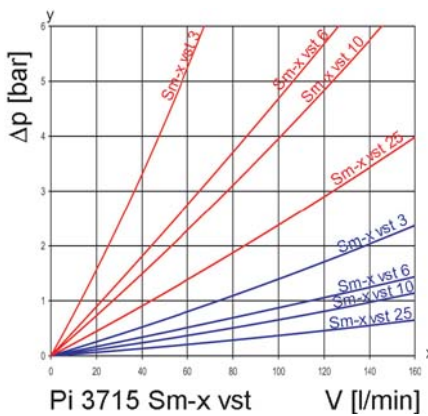
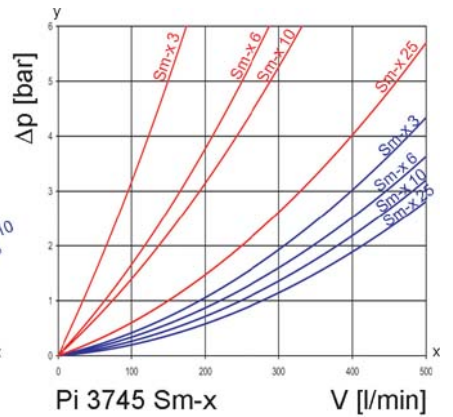
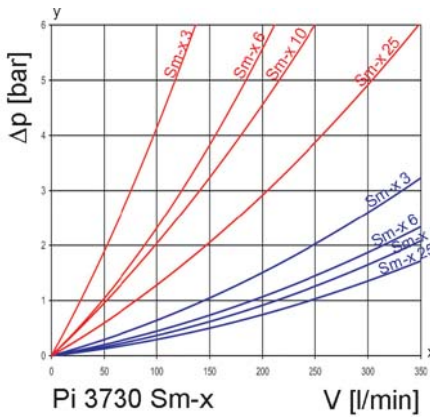
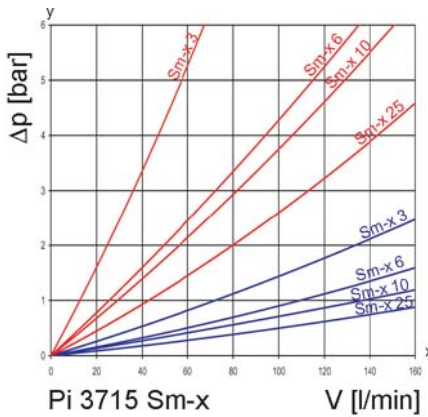
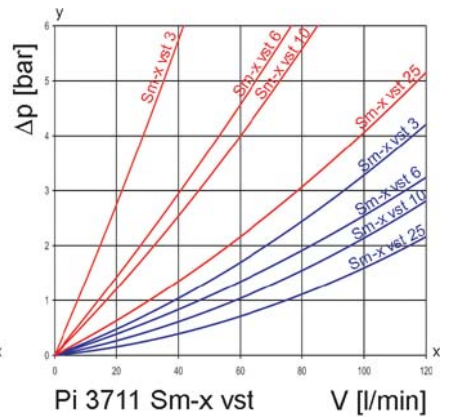
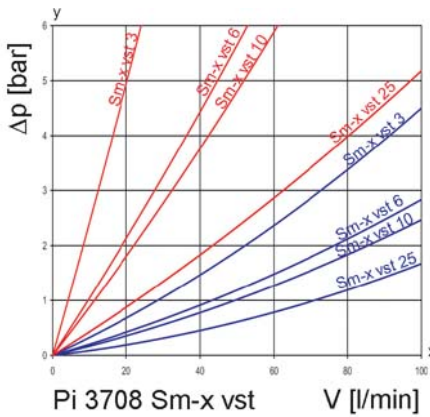
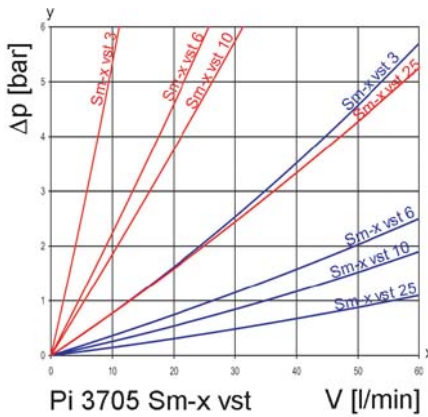
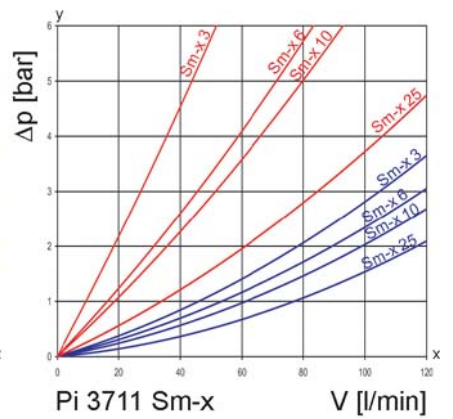
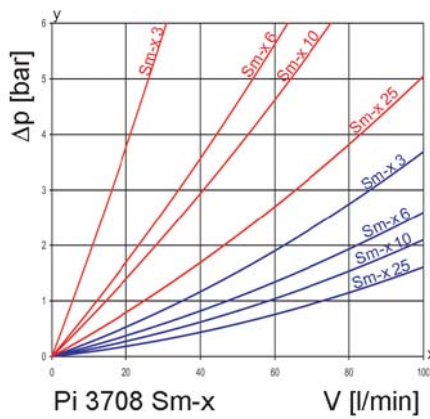
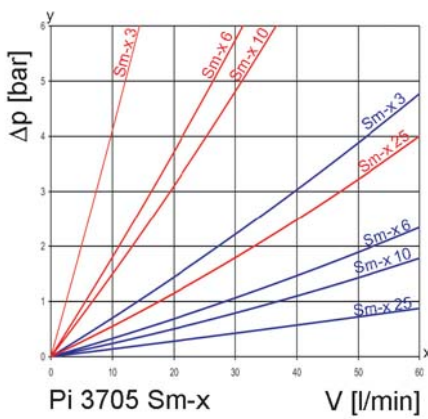

y = differential pressure Δp [bar]

x = flow rate V [l/min]

3. Separation characteristics

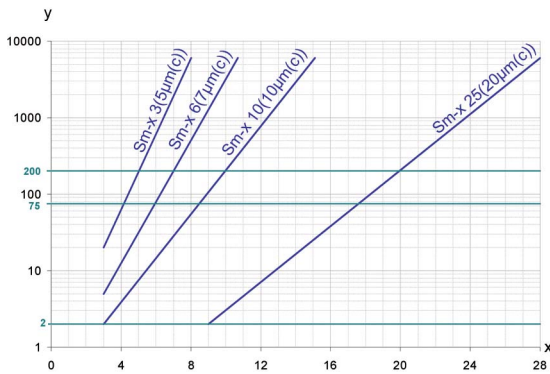

y = beta-ratio
x = particle size [μm]

determined by multipass test (ISO 16889)
calibration according to ISO 11171 (NIST)

4. Filter performance data

measured according to ISO 16889 (multipass test)

Sm-x elements with
 Δp 20 bar

Sm-x 3 $\beta_{5(C)} \geq 200$
Sm-x 6 $\beta_{7(C)} \geq 200$
Sm-x 10 $\beta_{10(C)} \geq 200$
Sm-x 25 $\beta_{20(C)} \geq 200$

up to 10 bar differential
pressure

Sm-x vst elements with
 Δp 210 bar

Sm-x vst 3 $\beta_{5(C)} \geq 200$
Sm-x vst 6 $\beta_{7(C)} \geq 200$
Sm-x vst 10 $\beta_{10(C)} \geq 200$
Sm-x vst 25 $\beta_{20(C)} \geq 200$

up to 20 bar differential
pressure

5. Quality assurance

MAHLE filter and filter elements are manufactured respectively, tested in accordance with the following international standards:

Norm	Designation
DIN ISO 2941	Hydraulic fluid power filter elements; verification of collapse/burst pressure
DIN ISO 2942	Hydraulic fluid power filter elements; verification of fabrication integrity
DIN ISO 2943	Hydraulic fluid power filter elements; verification of material compatibility with fluids
DIN ISO 3723	Hydraulic fluid power filter elements; method for end load test
DIN ISO 3724	Hydraulic fluid power filter elements; verification of flow fatigue characteristics
ISO 3968	Hydraulic fluid power filter; evaluation of pressure drop versus flow characteristics
ISO 10771.1	Fatigue pressure testing of metal containing envelopes in hydraulic fluid applications
ISO 16889	Hydraulic fluid power filters; multipass method for evaluation filtration performance of a filter element

6. Symbols

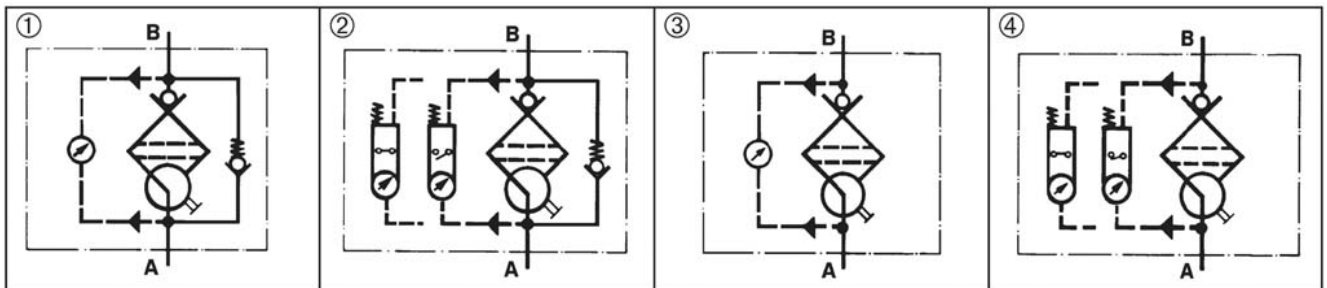

7. Order numbers

Example for ordering filters:

1. Housing design	2. 2x Filter elements
V = 80 l/min and electrical contamination indicator Type: Pi 3708-15 Order number: 77810369	Sm-x vst 3 Type: Pi 2208 Sm-x vst 3 Order number: 77680200

7.1 Housing design						
Nominal size NG [l/min]	Order number	Type	① with bypass valve and optical indicator	② with bypass valve and electrical indicator	③ with optical indicator	④ with electrical indicator
50	77810294	Pi 3705-012				
	77810302	Pi 3705-013				
	77810310	Pi 3705-014				
	77810328	Pi 3705-015				
80	77810336	Pi 3708-012				
	77810344	Pi 3708-013				
	77810351	Pi 3708-014				
	77810369	Pi 3708-015				
110	77810377	Pi 3711-012				
	77810385	Pi 3711-013				
	77810393	Pi 3711-014				
	77810401	Pi 3711-015				
150	77810419	Pi 3715-012				
	77810427	Pi 3715-013				
	77810435	Pi 3715-014				
	77810443	Pi 3715-015				
300	77810450	Pi 3730-012				
	77810468	Pi 3730-013				
	77810476	Pi 3730-014				
	77810484	Pi 3730-015				
450	77810492	Pi 3745-012				
	77814403	Pi 3745-013				
	77814411	Pi 3745-014				
	77814429	Pi 3745-015				

When filter with non bypass configuration is selected the collapse pressure of the element may not be exceeded.

7.2 Filter elements*					
Nominal size NG [l/min]	Order number	Type	Filter material	Collapse pressure [bar]	Filter surface [cm ²]
50	77680135	Pi 2105 Sm-x 3	Sm-x 3	20	590
	77943509	Pi 5105 Sm-x 6	Sm-x 6		590
	77680325	Pi 3105 Sm-x 10	Sm-x 10		590
	77680440	Pi 4105 Sm-x 25	Sm-x 25		590
	77680192	Pi 2205 Sm-x vst 3	Sm-x vst 3	210	425
	77943533	Pi 5205 Sm-x vst 6	Sm-x vst 6		425
	77680382	Pi 3205 Sm-x vst 10	Sm-x vst 10		425
	77680507	Pi 4205 Sm-x vst 25	Sm-x vst 25		425
80	77680143	Pi 2108 Sm-x 3	Sm-x 3	20	1150
	77943517	Pi 5108 Sm-x 6	Sm-x 6		1150
	77680341	Pi 3108 Sm-x 10	Sm-x 10		1150
	77680457	Pi 4108 Sm-x 25	Sm-x 25		1150
	77680200	Pi 2208 Sm-x vst 3	Sm-x vst 3	210	850
	77943541	Pi 5208 Sm-x vst 6	Sm-x vst 6		850
	77681190	Pi 3208 Sm-x vst 10	Sm-x vst 10		850
	77680515	Pi 4208 Sm-x vst 25	Sm-x vst 25		850
110	77680150	Pi 2111 Sm-x 3	Sm-x 3	20	1700
	77943525	Pi 5111 Sm-x 6	Sm-x 6		1700
	77680333	Pi 3111 Sm-x 10	Sm-x 10		1700
	77680456	Pi 4111 Sm-x 25	Sm-x 25		1700
	77680218	Pi 2211 Sm-x vst 3	Sm-x vst 3	210	1275
	77943558	Pi 5211 Sm-x vst 6	Sm-x vst 6		1275
	77680390	Pi 3211 Sm-x vst 10	Sm-x vst 10		1275
	77680523	Pi 4211 Sm-x vst 25	Sm-x vst 25		1275
150	77680168	Pi 2115 Sm-x 3	Sm-x 3	20	2425
	77955099	Pi 5115 Sm-x 6	Sm-x 6		2425
	77680358	Pi 3115 Sm-x 10	Sm-x 10		2425
	77680473	Pi 4115 Sm-x 25	Sm-x 25		2425
	77680226	Pi 2215 Sm-x vst 3	Sm-x vst 3	210	2010
	77955123	Pi 5215 Sm-x vst 6	Sm-x vst 6		2010
	77680408	Pi 3215 Sm-x vst 10	Sm-x vst 10		2010
	77680531	Pi 4215 Sm-x vst 25	Sm-x vst 25		2010
300	77680176	Pi 2130 Sm-x 3	Sm-x 3	20	4620
	77955107	Pi 5130 Sm-x 6	Sm-x 6		4620
	77680366	Pi 3130 Sm-x 10	Sm-x 10		4620
	77680481	Pi 4130 Sm-x 25	Sm-x 25		4620
	77680234	Pi 2230 Sm-x vst 3	Sm-x vst 3	210	3800
	77955131	Pi 5230 Sm-x vst 6	Sm-x vst 6		3800
	77680416	Pi 3230 Sm-x vst 10	Sm-x vst 10		3800
	77680549	Pi 4230 Sm-x vst 25	Sm-x vst 25		3800
450	77680184	Pi 2145 Sm-x 3	Sm-x 3	20	6865
	77955115	Pi 5145 Sm-x 6	Sm-x 6		6865
	77680374	Pi 3145 Sm-x 10	Sm-x 10		6865
	77680499	Pi 4145 Sm-x 25	Sm-x 25		6865
	77680242	Pi 2245 Sm-x vst 3	Sm-x vst 3	210	5600
	77955149	Pi 5245 Sm-x vst 6	Sm-x vst 6		5600
	77680424	Pi 3245 Sm-x vst 10	Sm-x vst 10		5600
	77680556	Pi 4245 Sm-x vst 25	Sm-x vst 25		5600

* further elements available upon request.

8. Specifications

Design:	line mounting filter
Operating pressure:	200 bar*
Test pressure:	260 bar
Temperature range:	-10 °C to +120 °C (other temperature ranges on request)
Bypass opening pressure:	Δp 7 bar \pm 10 %
Filter head material:	GGG
Filter bowl material:	St
Sealing material:	NBR/PTFE
Activating pressure of optical/ electrical differential pressure indicator:	Δp 5 bar \pm 10 %
Electrical data of contamination indicator:	
Maximum voltage:	250 V AC/200 V DC
Maximum current on contact:	1 A
Inrush current:	70 W
Type of protection:	IP 65 when inserted and secured
Contact:	bistable
Cable connection:	M 20 x 1.5

The switching function can be changed by turning the electric upper part by 180° (normally closed contact or normally open contact). The state on delivery is a normally closed contact. The use of quenching circuits must be checked in the case of inductivity in the DC current circuit. The contamination indicator data sheet contains further information and additional contamination indicator versions.

We draw attention to the fact that all values indicated are average values which do not always occur in specific cases of application. Our products are continually being further developed. Values, dimensions and weights can change as a result of this. Our specialized department will be pleased to offer you advice.

When using our filters in areas which are to be classified according to EU Directive 94/9 EC (ATEX 95), we recommend prior discussion with us. The standard version can be used for liquids based on mineral oil (corresponding to the fluids in Group 2 of Directive 97/23 EC Article 9). Please consult with us if using other media.

Subject to technical alteration without prior notice.

* Types Pi 3705-.. bis Pi 3711-.. have an operating pressure of 250 bar (test pressure 325 bar).

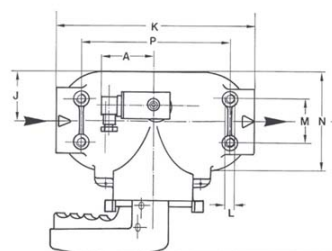
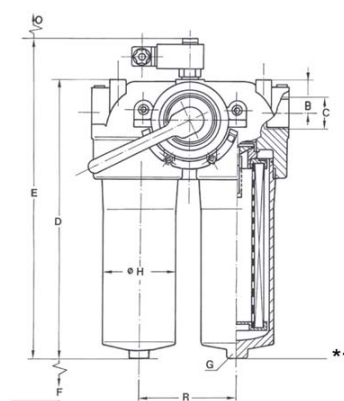

*1 Pi 3730-Pi 3745 with drain screw G 1/4 DIN 910

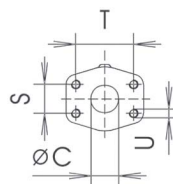

9. Dimensions

All dimensions except "C" in mm.

Type	A	B	C*	D	E	F	Weight [kg]
Pi 3705	78	38	G 1	219	271	80	11.0
Pi 3708	78	38	G 1	294	346	80	12.0
Pi 3711	78	38	G 1	370	422	80	15.0
Pi 3715	78	50	G 1 1/2	302	354	110	31.5
Pi 3730	78	50	G 1 1/2	427	479	110	37.0
Pi 3745	78	50	G 1 1/2	543	554	110	41.5

* SAE flange connection on request.

Type	G SW	H	I	J	K	L	M	N	O	P	R	S	T	U	Weight [kg]
Pi 3705	27	65	144	45	182	M 8 x 15	55	90	45	100	86	-	-	-	11.0
Pi 3708	27	65	144	45	182	M 8 x 15	55	90	45	100	86	-	-	-	12.0
Pi 3711	27	65	144	45	182	M 8 x 15	55	90	45	100	86	-	-	-	15.0
Pi 3715	30	110	175	70	280	M 12 x 18	62	140	45	210	136	-	-	-	31.5
Pi 3730	30	110	175	70	280	M 12 x 18	62	140	45	210	136	-	-	-	37.0
Pi 3745	30	110	175	70	280	M 12 x 18	62	140	45	210	136	35,7	69.85	M 12 x 20	41.5

10. Installation, operating and maintenance instructions

10.1 Filter installation

Install filter in accordance with the identified flow direction. The filter head is provided with threaded holes for mounting the filter. Ascertain that the required underclearance is provided so that the filter element and the filter bowl can be removed. Preferably the filter should be installed with the filter bowl pointing downwards. The contamination indicator must be visible.

10.2 Connecting the electrical contamination indicator

The electrical indicator is connected via a 2-pole appliance plug according to DIN EN 175301-803 with poles marked 1 and 2. The electrical section can be inverted to change from normally open to normally closed position or vice versa.

10.3 When must the filter element be replaced?

- Filters equipped with optical and electrical contamination indicator: During cold starts, the indicator may give a warning signal. Depress the red button of the optical indicator once again only after operating temperature has been reached. If the red button immediately pops out again and/or the electrical signal has not switched off after reaching operating temperature the filter element must be replaced after the end of the shift.
- Please always ensure that you have Original MAHLE replacement elements in stock: disposable elements (Sm-x) cannot be cleaned.

10.4 Element replacement

Note: The contamination indicator monitors the filter side in operation, which is identified by the position of the switching lever catch. The change-over transfer valve must be switched prior filter servicing. Now the signal of the contamination indicator is cancelled and the red button can be repressed again:

- Operate and hold pressure equalizing lever located behind switching lever. Pull catch knob and swivel switching lever. Engage the catch on the clear filter side. Place through or drip pan underneath to collect leaving oil.
- Loosen vent screw of the filter side not in use by 2-3 turns; max. until contact is made with the safety stop.
- Unscrew filter bowl by rotating same counterclockwise and clean with a suitable medium.
- Remove filter element with a side-to-side motion.
- Check o-ring on the filter bowl for damage. Replace, if necessary.
- Make sure that the part number on the spare element corresponds with the part number on the filter label. Open the plastic bag and push element over the spigot in the filter head. Now remove plastic bag.
- Complete installation by screwing on the bowl, turning clockwise until it comes to a full stop. Back off the bowl 1/8 to 1/2 turn.
- To refill the filter chamber, operate only the pressure equalizing lever (leave the switching lever arrested in its catch) long enough for the medium to emerge bubble-free from the vent bore.
- Tighten vent screw. Check filter for leaks by operating the pressure equalizing lever once again.

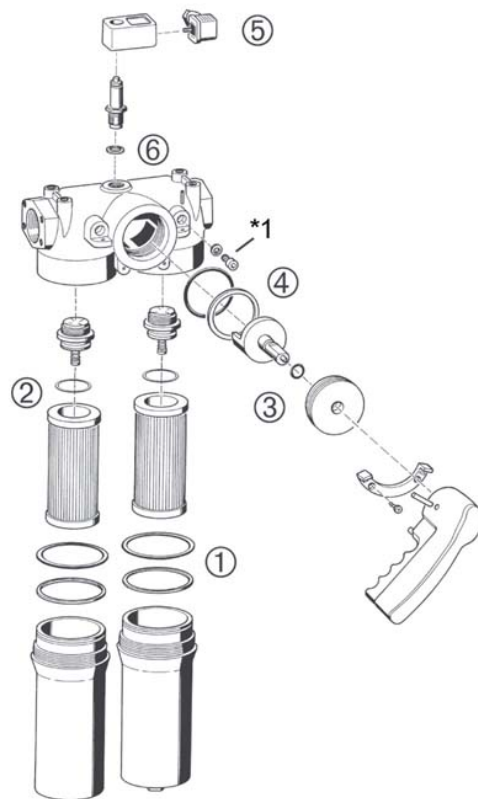

*1 vent screw

11. Spare parts list

Order numbers for spare parts		
Position	Type	Order number
① - ④	Seal kit	
	Pi 3705 - Pi 3711	
	NBR	78305062
	FPM	78305054
	EPDM	78305047
	Pi 3715 - Pi 3745	
	NBR	79375056
	FPM	79375064
	EPDM	79375072
⑤	Contamination indicator	
	Optical PiS 3093/5	77669914
	Electrical PiS 3092/5	77669864
	Electrical upper section only	77536550
⑥	Seal kit for contamination indicator	
	NBR	77760275
	FPM	77760283
	EPDM	77760291

Please return filter for sealing replacement of switch-over unit!

MAHLE

Industrial Filtration

MAHLE Filtersysteme GmbH
Industriefiltration
Schleifbachweg 45
D-74613 Öhringen
Phone +49 (0) 7941/67-0
Fax +49 (0) 7941/67-23429
industriefiltration@mahle.com
www.mahle-industriefiltration.com
78356909.11/2006