

Low Pressure Filter

Pi 200

Operating pressure 25/63 bar, Nominal size up to 450

1. Features

Efficient filters for modern hydraulic systems

- Modular design principle
- Compact design
- Minimal pressure drop
- Optical/electrical/electronic differential pressure indication
- Thread connection

Quality filters, easy to service

- Equipped with highly efficient Sm-x filter elements
- β -valued elements per ISO 16889
- High dirt holding capacity and differential pressure stability providing optimal element service life

Worldwide distribution



2. Flow rate/pressure drop curve complete filter

■ 190 mm²/s (25° E)
■ 33 mm²/s (4,5° E)

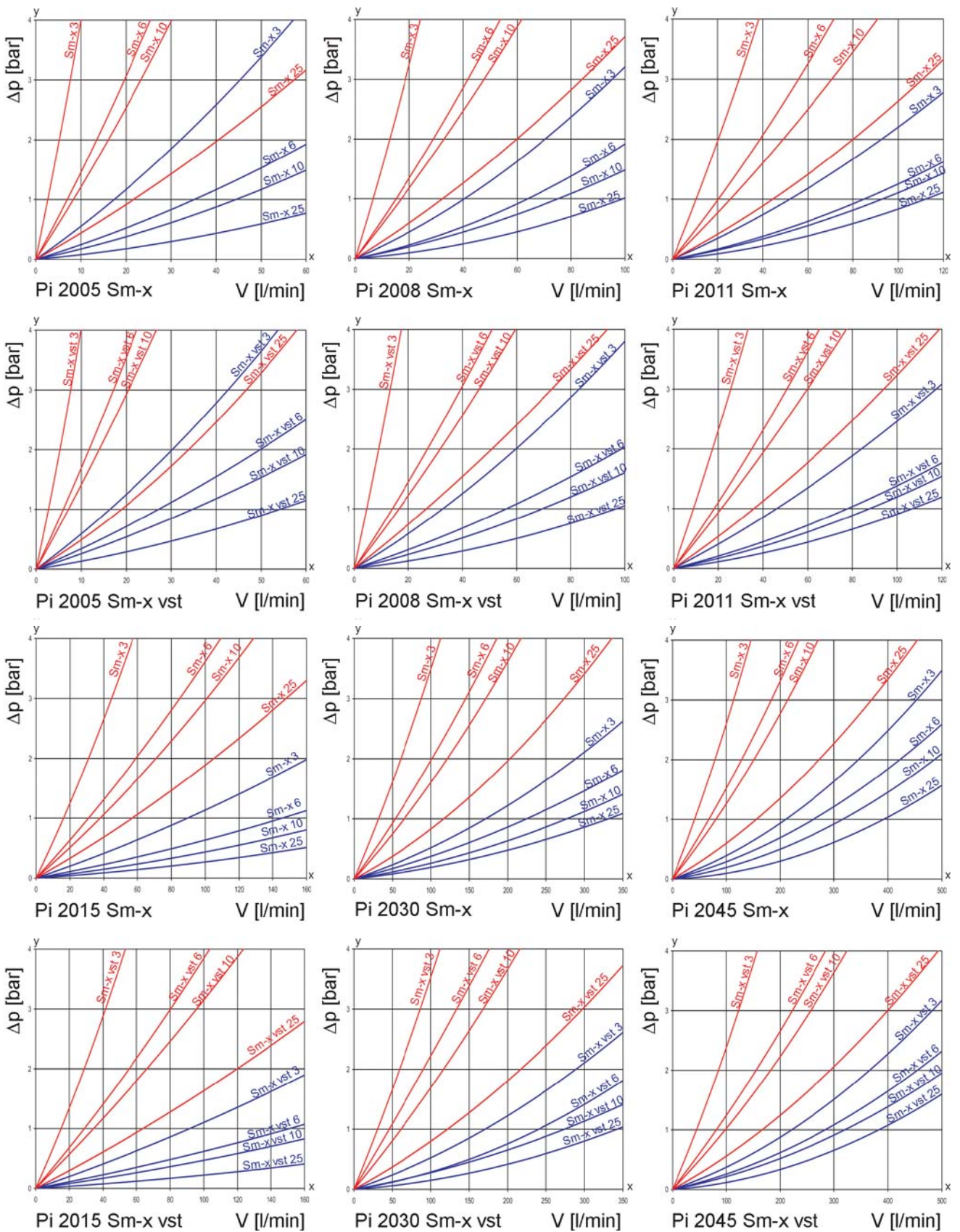

y = differential pressure Δp [bar]

x = flow rate V [l/min]

3. Separation characteristics

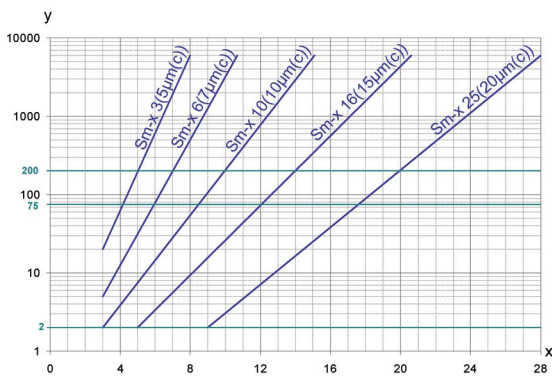

y = beta-ratio
x = particle size [μm]

determined by multipass tests (ISO 16889)
calibration according to ISO 11171 (NIST)

4. Filter performance data

measured according to ISO 16889 (multipass test)

Sm-x elements with
 Δp 20 bar

Sm-x	3	$\beta_{5(C)}$	≥ 200
Sm-x	6	$\beta_{7(C)}$	≥ 200
Sm-x	10	$\beta_{10(C)}$	≥ 200
Sm-x	16	$\beta_{15(C)}$	≥ 200
Sm-x	25	$\beta_{20(C)}$	≥ 200

up to 10 bar differential
pressure

Sm-x vst elements with
 Δp 210 bar

Sm-x vst	3	$\beta_{5(C)}$	≥ 200
Sm-x vst	6	$\beta_{7(C)}$	≥ 200
Sm-x vst	10	$\beta_{10(C)}$	≥ 200
Sm-x vst	16	$\beta_{15(C)}$	≥ 200
Sm-x vst	25	$\beta_{20(C)}$	≥ 200

up to 20 bar differential
pressure

5. Quality assurance

MAHLE filter and filter elements are manufactured respectively, tested in accordance with the following international standards:

Norm	Designation
DIN ISO 2941	Hydraulic fluid power filter elements; verification of collapse/burst resistance
DIN ISO 2942	Hydraulic fluid power filter elements; verification of fabrication integrity
DIN ISO 2943	Hydraulic fluid power filter elements; verification of material compatibility with fluids
DIN ISO 3723	Hydraulic fluid power filter elements; method for end load test
DIN ISO 3724	Hydraulic fluid power filter elements; verification of flow fatigue characteristics
ISO 3968	Hydraulic fluid power filters; evaluation of pressure drop versus flow characteristics
ISO 10771.1	Fatigue pressure testing of metal containing envelopes in hydraulic fluid applications
ISO 16889	Hydraulic fluid power filters; multipass method for evaluation filtration performance of a filter element

6. Symbols

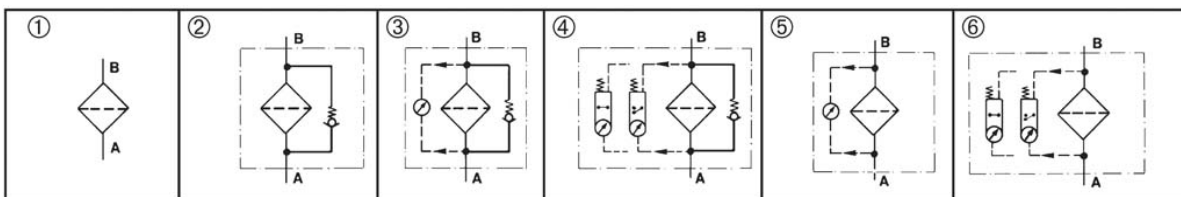

7. Order numbers

Example for ordering filters:

1. Housing design	2. Filter element
V = V=80 l/min and electrical indication Type: Pi 2008-69 Order number: 77665284	Sm-x vst 3 Type: Pi 2208 Sm-x vst 3 Order number: 77680200

7.1 Housing design								
Nominal size NG [l/min]	Order number	Type	① no options	② with bypass valve	③ with bypass valve and optical indi- cator	④ with bypass valve and electrical indicator	⑤ with electrical indicator	⑥ with electrical indicator
50	77665144	Pi 2005-060						
	77665110	Pi 2005-056						
	77665128	Pi 2005-057						
	77665136	Pi 2005-058						
	77665169	Pi 2005-068						
	77665177	Pi 2005-069						
80	77665235	Pi 2008-060						
	77665201	Pi 2008-056						
	77665219	Pi 2008-057						
	77665227	Pi 2008-058						
	77665276	Pi 2008-068						
	77665284	Pi 2008-069						
110	78205114	Pi 2011-060						
	78205122	Pi 2011-056						
	78205130	Pi 2011-057						
	78205148	Pi 2011-058						
	78205155	Pi 2011-068						
	78205163	Pi 2011-069						
150	77840580	Pi 2015-060						
	76165203	Pi 2015-056						
	76165211	Pi 2015-057						
	79320748	Pi 2015-058						
	76165229	Pi 2015-068						
	78396616	Pi 2015-069						
300	77665474	Pi 2030-060						
	77665441	Pi 2030-056						
	77665458	Pi 2030-057						
	77665466	Pi 2030-058						
	77665516	Pi 2030-068						
	77665532	Pi 2030-069						
450	77664881	Pi 2045-060						
	77664873	Pi 2045-056						
	77664865	Pi 2045-057						
	77664857	Pi 2045-058						
	77664923	Pi 2045-068						
	77664931	Pi 2045-069						

When filter with non bypass configuration is selected the collapse pressure of the element may not be exceeded.

Types Pi 2005 - Pi 2011 have an operating pressure of 63 bar/test pressure of 82 bar.

7.2 Filter elements*

Nominal size NG [l/min]	Order number	Type	Filter material	Collapse pressure [bar]	Filter surface [cm ²]
50	77680135	Pi 2105 Sm-x 3	Sm-x 3	20	590
	77943509	Pi 5105 Sm-x 6	Sm-x 6		590
	77680325	Pi 3105 Sm-x 10	Sm-x 10		590
	77680440	Pi 4105 Sm-x 25	Sm-x 25		590
	77680192	Pi 2205 Sm-x vst 3	Sm-x vst 3	210	425
	77943533	Pi 5205 Sm-x vst 6	Sm-x vst 6		425
	77680382	Pi 3205 Sm-x vst 10	Sm-x vst 10		425
	77680507	Pi 4205 Sm-x vst 25	Sm-x vst 25		425
80	77680143	Pi 2108 Sm-x 3	Sm-x 3	20	1150
	77943517	Pi 5108 Sm-x 6	Sm-x 6		1150
	77680341	Pi 3108 Sm-x 10	Sm-x 10		1150
	77680457	Pi 4108 Sm-x 25	Sm-x 25		1150
	77680200	Pi 2208 Sm-x vst 3	Sm-x vst 3	210	850
	77943541	Pi 5208 Sm-x vst 6	Sm-x vst 6		850
	77681190	Pi 3208 Sm-x vst 10	Sm-x vst 10		850
	77680515	Pi 4208 Sm-x vst 25	Sm-x vst 25		850
110	77680150	Pi 2111 Sm-x 3	Sm-x 3	20	1700
	77943525	Pi 5111 Sm-x 6	Sm-x 6		1700
	77680333	Pi 3111 Sm-x 10	Sm-x 10		1700
	77680456	Pi 4111 Sm-x 25	Sm-x 25		1700
	77680218	Pi 2211 Sm-x vst 3	Sm-x vst 3	210	1275
	77943558	Pi 5211 Sm-x vst 6	Sm-x vst 6		1275
	77680390	Pi 3211 Sm-x vst 10	Sm-x vst 10		1275
	77680523	Pi 4211 Sm-x vst 25	Sm-x vst 25		1275
150	77680168	Pi 2115 Sm-x 3	Sm-x 3	20	2425
	77955099	Pi 5115 Sm-x 6	Sm-x 6		2425
	77680358	Pi 3115 Sm-x 10	Sm-x 10		2425
	77680473	Pi 4115 Sm-x 25	Sm-x 25		2425
	77680226	Pi 2215 Sm-x vst 3	Sm-x vst 3	210	2010
	77955123	Pi 5215 Sm-x vst 6	Sm-x vst 6		2010
	77680408	Pi 3215 Sm-x vst 10	Sm-x vst 10		2010
	77680531	Pi 4215 Sm-x vst 25	Sm-x vst 25		2010
300	77680176	Pi 2130 Sm-x 3	Sm-x 3	20	4620
	77955107	Pi 5130 Sm-x 6	Sm-x 6		4620
	77680366	Pi 3130 Sm-x 10	Sm-x 10		4620
	77680481	Pi 4130 Sm-x 25	Sm-x 25		4620
	77680234	Pi 2230 Sm-x vst 3	Sm-x vst 3	210	3800
	77955131	Pi 5230 Sm-x vst 6	Sm-x vst 6		3800
	77680416	Pi 3230 Sm-x vst 10	Sm-x vst 10		3800
	77680549	Pi 4230 Sm-x vst 25	Sm-x vst 25		3800
450	77680184	Pi 2145 Sm-x 3	Sm-x 3	20	6865
	77955115	Pi 5145 Sm-x 6	Sm-x 6		6865
	77680374	Pi 3145 Sm-x 10	Sm-x 10		6865
	77680499	Pi 4145 Sm-x 25	Sm-x 25		6865
	77680242	Pi 2245 Sm-x vst 3	Sm-x vst 3	210	5600
	77955149	Pi 5245 Sm-x vst 6	Sm-x vst 6		5600
	77680424	Pi 3245 Sm-x vst 10	Sm-x vst 10		5600
	77680556	Pi 4245 Sm-x vst 25	Sm-x vst 25		5600

* further elements available upon request.

8. Specifications

Design:	line mounting filter
Operating pressure:	25/63 bar*
Test pressure:	33/82 bar
Temperature range:	-10 °C to +120 °C (other temperature ranges on request)
Bypass opening pressure:	Δp 3.5 bar \pm 10 %
Filter head material:	GDAL
Filter bowl material:	AL/St
Sealing material:	NBR/AL
Activating pressure of optical/ electrical differential pressure indicator:	Δp 2.2 bar \pm 10 %
Electrical data of contamination indicator:	
Maximum voltage:	250 V AC/200 V DC
Maximum current on contact:	1 A
Inrush current:	70 W
Type of protection:	IP 65 when inserted and secured
Contact:	bistable
Cable connection:	M 20 x 1.5

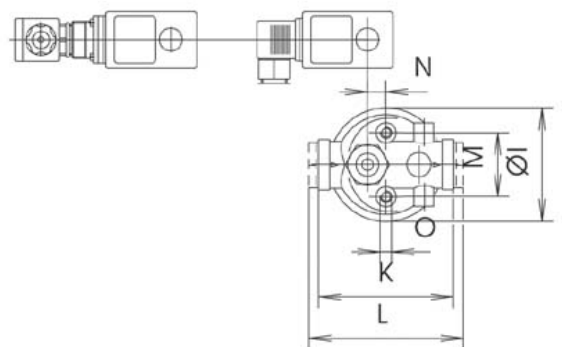
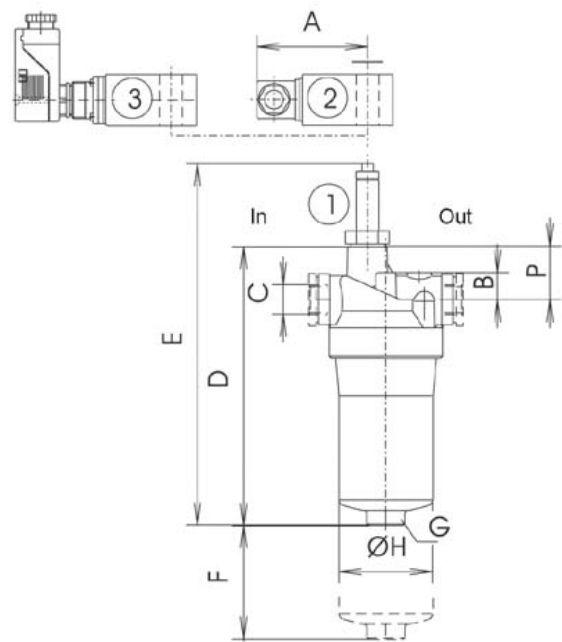

In = intake
Out = outlet

The switching function can be changed by turning the electric upper part by 180° (normally closed contact or normally open contact). The state on delivery is a normally closed contact. The use of quenching circuits must be checked in the case of inductivity in the DC current circuit. The contamination indicator data sheet contains further information and additional contamination indicator versions.

We draw attention to the fact that all values indicated are average values which do not always occur in specific cases of application. Our products are continually being further developed. Values, dimensions and weights can change as a result of this. Our specialized department will be pleased to offer you advice.

When using our filters in areas which are to be classified according to EU Directive 94/9 EC (ATEX 95), we recommend prior discussion with us. The standard version can be used for liquids based on mineral oil (corresponding to the fluids in Group 2 of Directive 97/23 EC Article 9). Please consult with us if using other media.

Subject to technical alteration without prior notice.

* Types Pi 2005 – Pi 2011 have an operating pressure of 63 bar/ test pressure 82 bar.

9. Dimensions

All dimensions except "C" in mm.

Type	A	B	C	D	E	F	G SW	H	I	K	L	M	N	O	P	Weight [kg]
Pi 2005	78	19	G ½	177	235	80	27	66	80	-	109	45	13	M 8 x 10	37.5	0.9
Pi 2008	78	19	G ¾	253	311	80	27	66	80	95	-	45	13	M 8 x 10	37.5	1.0
Pi 2011	78	19	G ¾	335	393	80	27	66	80	95	-	45	13	M 8 x 10	37.5	1.1
Pi 2015	78	30	G 1 ¼	246	304	110	32	109	128	150	-	60	24.5	M 12 x 15	43.5	2.1
Pi 2030	78	30	G 1 ¼	363	421	110	32	109	128	150	-	60	24.5	M 12 x 15	43.5	2.4
Pi 2045	78	30	G 1 ¼	478	536	110	24	109	128	150	-	60	24.5	M 12 x 15	43.5	6.5

10. Installation, operating and maintenance instructions

10.1 Filter installation

When installing the filter make sure that sufficient space is available to remove filter element and filter bowl.

Preferable the filter should be installed with the filter bowl pointing downwards.

The contamination indicator must be visible.

10.2 Connecting the electrical contamination indicator

The electrical indicator is connected via a 2-pole appliance plug according to DIN EN 175301-803 with poles marked 1 and 2.

The electrical section can be inverted to change from normally open position to normally closed position or vice versa.

10.3 When must the filter element be replaced?

- Filters equipped with optical and electrical contamination indicator:
During cold starts, the indicator may give a warning signal. Depress the red button of the visual indicator once again only after operating temperature has been reached. If the red button immediately pops out again and/or the electrical signal has not switched off after reaching operating temperature, the filter element must be replaced after the end of the shift.
- Filters without contamination indicator:
The filter element should be replaced after the trial run or flushing of the system. Afterwards follow instructions of the manufacturer.
- Please always ensure that you have Original MAHLE replacement elements in stock: disposable elements (Sm-x) cannot be cleaned.

10.4 Element replacement

- Stop system and relieve filter from pressure.
- Unscrew the filter bowl by turning counter-clockwise. Clean the bowl using a suitable cleaning solvent.
- Remove filter element with a side-to-side motion.
- Check O-ring on the filter bowl and spigot for damage. Replace, if necessary.
- Make sure that the order number on the spare element corresponds with the order number of the plate of the filter. Open the plastic bag and push element over the spigot in the filter head. Now remove plastic bag.
- Complete installation by oiling and screwing on the bowl, turning clockwise until it comes to a full stop. Back off the bowl to turn.

caption

Pos. 1 Visual contamination indicator

Pos. 2 El. upper section connector according DIN EN 175301-803, Execution: PiS 3097, 3116, 3119

Pos. 3 El. upper section connector according DIN EN 175201-804, Execution: PiS 3012, 3124, 3110

Connection M 12 x 1

Execution: PiS 3116 M 12 x 1, PiS 3151, 3154

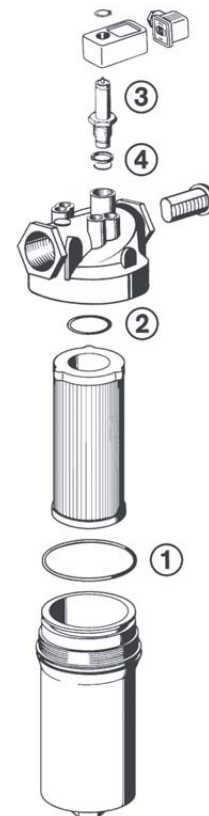

11. Spare parts list

Order numbers of spare parts		
Position	Type	Order number
①	Seal kit for filter	
-	Pi 2005 - Pi 2011	
②	NBR	77550213
	FPM	77845795
	EPDM	77845803
	Pi 2015 - Pi2045	
	NBR	77550221
	FPM	77845811
	EPDM	77845829
④	Contamination indicator	
	Optical PiS 3098/2.2	77669971
	Electrical PiS 3097/2.2	77669948
	Electrical upper section only	77536550
⑤	Seal kit for contamination indicator	
	NBR	77760309
	FPM	77760317
	EPDM	77760325

MAHLE

Industrial Filtration

MAHLE Filtersysteme GmbH
Industriefiltration
Schleifbachweg 45
D-74613 Öhringen
Phone +49 (0) 7941/67-0
Fax +49 (0) 7941/67-23429
industriefiltration@mahle.com
www.mahle-industriefiltration.com
78356446.11/2006