



Specialists in Liquid Level Indication

# MTII4200 level Transmitter

## Installation, Operation & Maintenance Instructions

Section:	M500
Bulletin:	M500.31
Date:	01-26-12
Supersedes:	04-22-08

### 1. INTRODUCTION

The Jerguson Model MTII4200 is a 4-20 mA, loop-powered HART compatible level transmitter intended to be used in conjunction with the Jerguson Magnicator II magnetic liquid level gage.

The part number designator for the MTII4200 can be found below.

### MODEL NUMBER DESIGNATION

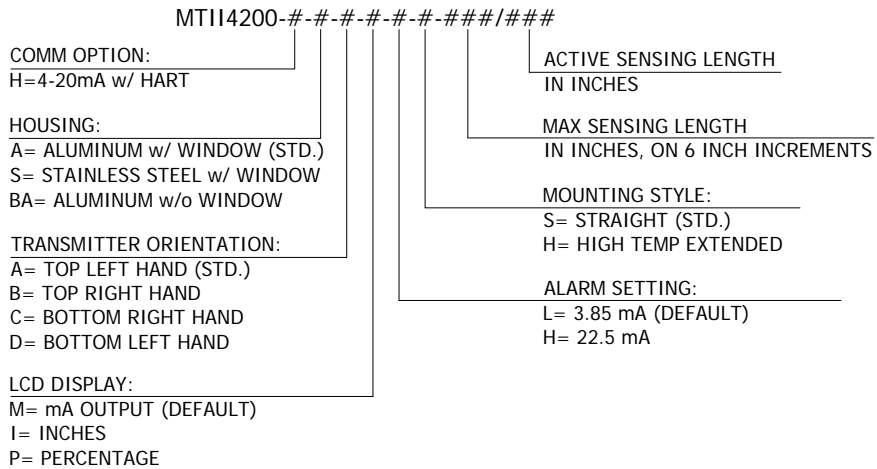

There are two main components that make up the MTII4200. These two components are the electronics housing and the sensor housing (see Figs. 1 & 2). These two components are assembled at the factory and should not be separated in the field.

Figure 1. MTII4200-H-A-D-x-x-S-xxx/xxx Straight Bottom Left Hand Assembly

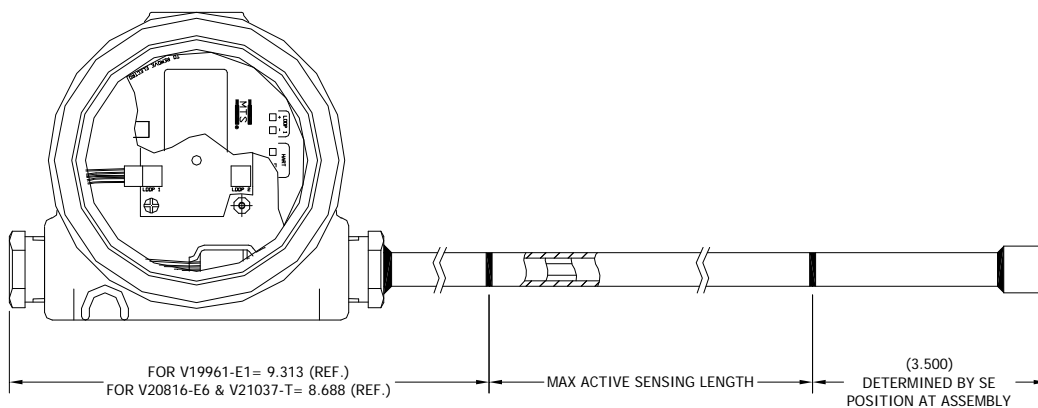
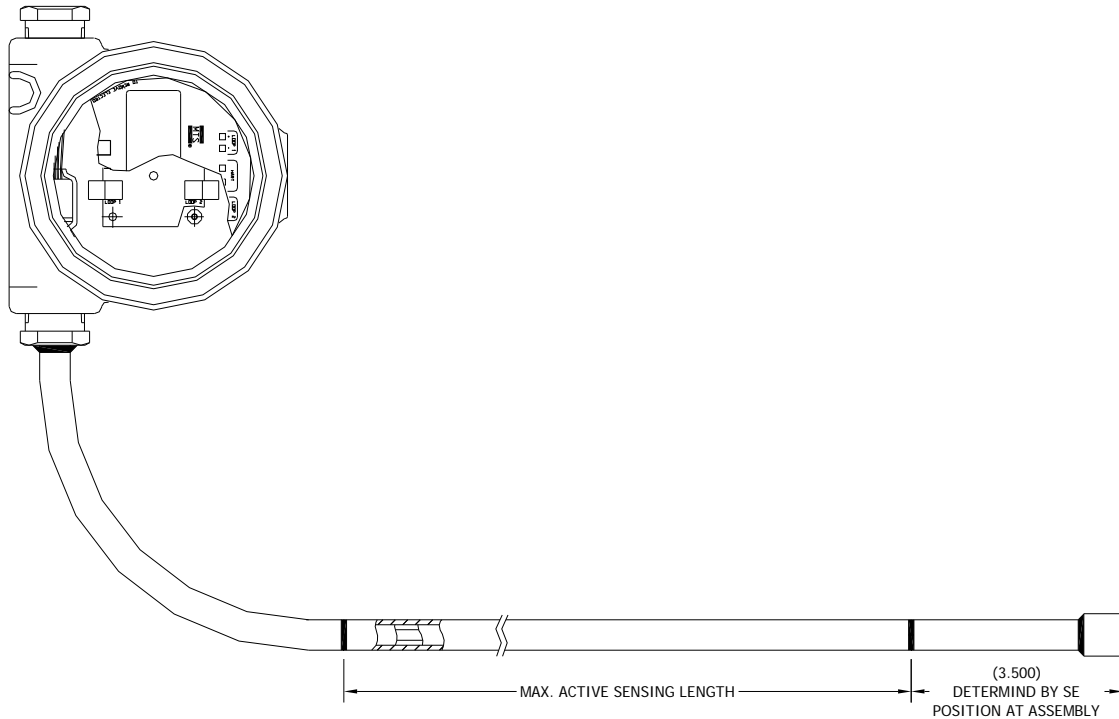

Figure 2. MTII4200-H-A-D-x-x-H-xxx/xxx Bent Bottom Left Hand Angled Assembly



## 2. PRODUCT DESCRIPTION

The MTII4200 liquid level sensor is a multifunctional transmitter with 4-20 mA loop and HART. It provides an analog output of level and the HART digital protocol. Outputs can be monitored using 4-20 mA signal output, a HART device (hand-held or PC-compatible software), the integral display, or all of the above. The MTII4200 transmitters are available in a single cavity explosion-proof enclosure.

### 2.1 MTII4200 Transmitter Specifications

<u>PARAMETER</u>	<u>SPECIFICATIONS</u>
<b><u>LEVEL OUTPUT</u></b>	
<b>Measured Variable:</b>	Liquid level, interface level
<b>Output:</b>	4-20 mA, HART
<b>Full Range:</b>	12 to 228 in. (46 to 579 cm) for mounting style S 12 to 144 in. (46 to 365 cm) for mounting style H
<b>Non-linearity:</b>	0.020% F.S. (Independent BSL) or 1/32 in. (0.794 mm)*
<b>Repeatability:</b>	0.005% F.S. or 0.005 in. (0.127 mm)*
<b>Sensor Operating Temperature:</b>	-40 to 300°F (-40 to 149°C) Ambient
<b><u>GAUGE LOOP</u></b>	
<b>Input Voltage Range:</b>	10.5 to 36 VDC
<b>Reverse Polarity Protection:</b>	Series diodes
<b>Transient Protection:</b>	Stage 1: line-to-ground surge suppressors; 2500 Amps peak (8/20 µsec.) Stage 2: line-to-line and line-to-ground transient suppressors; 1500 Watts peak (10/1000 µsec.)
<b><u>CALIBRATION</u></b>	
<b>Zero Adjust Range:</b>	Anywhere within the active length
<b>Span Adjust Range:</b>	Full Scale 0.5 ft. (152 mm) from zero

### ENVIRONMENTAL

**Humidity:** 0 to 100% R.H., non-condensing  
**Electronics Operating Temperature:** -30 to 160°F (-34 to 71°C) ambient  
**Vessel Pressure:** Dependent on float pressure rating,

### FIELD INSTALLATION

**Mounting:** 3/4 in. NPT fitting or flange mounting  
**Wiring:** 2-wire connection, shielded cable or twisted pair to screw terminals through a 3/4 in. NPT conduit opening

### DISPLAY

**Measured Variables:** Level  
**Update Rate:** 3 seconds

### HART COMMUNICATIONS

**Method of Communication:** Frequency Shift Keying (FSK) conforms with Bell 202 Modem Standard with respect to baud rate and digital "1" and "0" frequencies.  
**Baud Rate:** 1200 BPS  
**Digital "0" Frequency:** 2200 Hz  
**Digital "1" Frequency:** 1200 Hz  
**Data Byte Structure:** 1 Start Bit, 8 Data Bits, 1 Odd Parity Bit, 1 Stop Bit  
**Digital Process Variable Rate:** Poll/Response Model 2.0 per second

### AGENCY APPROVALS

**Factory Mutual (FM)** Explosion-proof:  
Class I, Div 1, Groups B, C, D  
Class II, Div 1, Groups E, F, G  
Class III

## 2.2 Theory of Operation

The MTII4200 transmitters precisely sense the position of an external float by applying an interrogation pulse to a waveguide medium. This current pulse causes a magnetic field to instantly surround the waveguide. The magnet installed within the float also creates a magnetic field. Where the magnetic fields from the waveguide and float intersect, a rotational force is created (waveguide twist). This, in turn, creates a torsional sonic pulse that travels along the waveguide. The head of the transmitter houses the sensing circuit, which detects the torsional sonic pulse and converts it to an electrical pulse. The distance from a reference point to the float is determined by measuring the time interval between the initiating current pulse and the return pulse and knowing the precise speed of these pulses. The time interval is converted into a 4 - 20 mA loop signal.

## 3. INSTALLATION/MOUNTING

### Mounting

The MTII4200 is designed to mount directly to the outside of the Magnicator II chamber.

1. Secure the transmitter to the chamber using the supplied hose clamps.
2. Align the low and high level range markings on the sensor housing with the actual measurement range .
3. Ensure that the clamps are tight.
4. To test if the gauge is properly tightened, pull up on the electronics housing. The gauge should not move.

## 4. ELECTRICAL CONNECTIONS AND WIRING PROCEDURES

### Electrical Connections

Connect the 24 VDC power supply to the electronics module using the screw terminal block on the electronics module. A typical wiring arrangement is shown in Figure 3.

Figure 3 Wiring Diagram

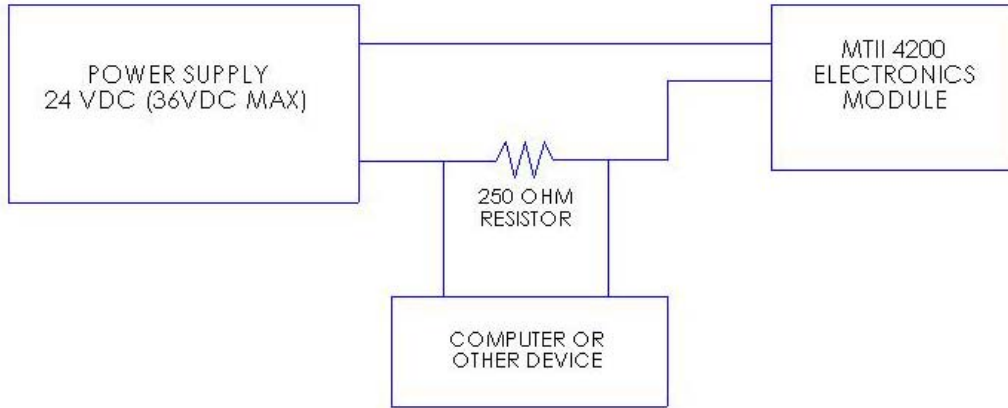

For explosion-proof installations, wiring shall be in accordance with the National Electric Code ANSI/NFPA 70, Article 501-30.

Shielded cable, twisted pair of 24 AWG or heavier should be used. Cable capacitance shall be less than 30 pF per foot.

### 4.1 Cable Specifications

#### Parameter Specification

Minimum Cable Size: 24 AWG or heavier (0.51 mm diameter)

Cable Type: Single pair shielded or multiple pair with overall shield

Maximum Cable Length: Twisted Pair: 10,000 ft. (3,048 m)

Multiple Twisted-Pair: 5,000 ft. (1,524 m)

### 4.2 Safety Recommendations for MTII4200 Transmitter

Always follow applicable local and national electrical codes and observe polarity when making electrical connections. Never make electrical connections to the MTII4200 transmitter with power turned on. Make sure that no wire strands are loose or sticking out of the terminal block connection which could short and cause a problem. Make sure that no wire strands, including shield, are in contact with the electronic module enclosure. The electronics module enclosure is grounded through internal circuitry and electrically isolated from the explosion-proof enclosure.

## 5. SYSTEM CHECK

After completing the MTII4200 wiring, the system is ready to be checked out. Apply power to the unit. Using a DC voltmeter, measure the voltage at loop #1 connections. The voltage must be 10.5V. If the voltage levels are too low, shut down the system. Check for shorts, power supply voltage, and excessive loop resistance.

### 5.1 Loop #1 Test

To test loop #1 on a bench, move the float along the operational range of the MTII4200 transmitter. If functioning properly, the output current will change as the float moves.

An output current of less than 4 mA or greater than 20 mA could indicate a problem with the MTII4200 transmitter.

## 6. MAINTENANCE

Magnicator II liquid level gauges use magnetostrictive technology and only have one moving part—the float. This technology ensures no scheduled maintenance or re-calibration is required.

### 6.1 Removal of Electronic Puck

The MTII4200 gauge is designed so that the user may remove the electronics module for any reason, including repair or upgrading of the module. Use the instructions below to remove the MTII4200 electronics module.

1. Remove power from gauge.
2. Remove cover from explosion-proof housing enclosure.
3. Gently pull out the electronic puck by raising equally on all sides of the round puck. Do not twist.
4. Pull electronic puck completely free of connector pins and spacer on block cover.

### 6.2 Installation of Electronic Puck

Use the instructions below to install the MTII4200 electronics module.

1. Remove power from gauge.
2. Remove cover from explosion-proof housing enclosure.
3. Place electronics puck on top of mating connector pins (2 places) and spacer, and gently press down on puck.
4. Press down on puck until connection is made completely.
5. Install cover of enclosure before applying power.

## 7. ADJUSTMENTS FOR MTII4200 TRANSMITTERS (via HART)

Refer to the documentation supplied with your specific HART software package or hand held communicator for details on performing sensor calibration. This section describes how the HART protocol is applied to the MTII4200 level transmitter only.

Using the HART interface allows for calibration without having to remove the transmitter from the process and position the floats. The HART commands 35 and 65 are implemented for this function.

Any measured output may be assigned to any variable. Loop #1 is always the primary variable (P.V.); normally level one is assigned to loop #1.

Calibration set points for level one are given as the absolute displacement (in the appropriate units) from the tip of the sensor. For example, if the desired ZERO position for level one is given as 5 inches, the MTII4200 will produce 4 mA when the float is 5 inches from the tip of the transmitter. If the desired SPAN position for level one is given as 30 inches, the MTII4200 will produce 20 mA when the float is 35 inches from the tip of the transmitter.

### 7.1 HART Quick Start

The MTII4200 transmitter can be re-calibrated using a Rosemount model 275 hand held terminal. Follow the simple instructions below to reset the low and high values for loop #1. Only loop #1 can be calibrated with the HART terminal.

#### RULES:

1. Be sure the MTII4200 is connected to a clean 24 VDC power supply. Use a linear supply; switching types do not provide ripple-free power. HART cannot tolerate more than a 25 mV voltage ripple.
2. If the unit is installed in a live application, place your automatic controllers in manual mode and be advised that the output current will change during calibration.
3. Follow safe working procedures as applicable for working on live equipment in a hazardous location. When safety is secured, remove housing cover.
4. Connect the HART communicator to the HART terminals labeled "HART" on the front panel display of the MTII4200 gauge.

**NOTE:** Be sure you have the transmitter loop #1 connected to a load of 250 to 500 Ohms. A unit installed in a control loop is a good example of this loop load. You may also use a load resistor in the range of the above value.

5. Press the black and white "I/O" button on the HART terminal. The terminal will go into self-test, then into the main screen. If not connected properly, you will get a "No device found" message.

6. From the main screen, press keypad key #1, "Device Setup".

7. From the "Device Setup" screen, press key #3, "Basic Setup".

8. Press key #3. You are now in "Range Values" screen.

### To set low value

To set the low value (4 mA), select key #1, PV LRV (Process Variable, Lower Range Value). You are now in the PV LRV screen. The current low value is displayed. Below this value is a highlighted value. Key in the desired low value (example 3.00 in. is shown; if 4 inches is desired, key in 4.) When the new desired low value is keyed in, press the "enter" (F4) button located below the LCD display, right. To write the changed lower value to memory, press the "SEND" key now. Next you will see two "WARNING" screens that ask if you are sure. If your new low values are correct, press "OK" for both messages. This action resets the Lower Range Value, or 4 mA position into the transmitter's memory. Go back to the "Range Values" screen to verify that the new parameters have been accepted into the transmitter memory.

You may now exit program mode or continue on to reset the upper value. If you choose to exit the program mode, replace the calibration jumper to the "ON" position, and return your controllers to automatic.

### To set high value

You should now be in the "Range Values" screen. To set the 20 mA (Upper Range), press key #2. You are now in the "PV URV" (Process Variable, Upper Range Value) screen. As in the lower value screen, the current value is displayed with a highlighted number below it. To change the upper value, key in the desired value. You may use whole numbers or whole numbers and decimal numbers (40 = 40 inches, or 40.5 = 40.50 inches). Whole numbers will be entered as their decimal equivalents by HART automatically. Key in the desired upper range value desired. Press the "Enter" (F4) button.

You are back in the "Range Values" screen. If the numbers for lower and upper are correct, press the "Send" key. You will get a "WARNING!" Press the "OK" button. You will again get "WARNING!" Press "OK" again.

Startup is now complete.

**CAUTION!** Do not enter a high value that exceeds the active length of the sensor!

## 7.2 Calibration

The MTII4200 has three buttons for calibration:

← Enter	Pressing any button will cause the unit to enter calibration.
▼ Down Arrow	Pressing all three buttons at any one time will exit the calibration mode.
▲ Up Arrow	

- 1.) Turn the power on to the unit.
- 2.) Wait for the self-diagnostics to complete.
- 3.) Press any button to start calibration mode.
- 4.) The screen will display "Cal Lev 1?".
- 5.) The far right button is the "Enter" key.
- 6.) Press the Enter key.
- 7.) The screen will display "Set Zero?".
- 8.) Move the float to the zero, (4mA), location.
- 9.) Press the Enter key.
- 10.) The screen will display "Zero (corresponding number)".
- 11.) Press Enter to reset the (corresponding number) to zero and hold for approximately 1-2 seconds.
- 12.) The screen will display "Accept?".
- 13.) Press Enter (You have now set the zero point).
- 14.) The screen will display "Cal Lev 1?".
- 15.) Press Enter.
- 16.) The screen will display "Set Zero?".

### The Clark Reliance Corporation

16633 Foltz Industrial Parkway | Strongsville, OH 44149 | Telephone +1 (440) 572-1500 Facsimile: +1 (440)-238-8828  
Email: [sales@clark-reliance.com](mailto:sales@clark-reliance.com) | Web Site: [www.clark-reliance.com](http://www.clark-reliance.com)

- 17.) Press the arrow UP key (far left) so the screen will now display "Set Span?".
- 18.) Move the float to the span location.
- 19.) Press Enter.
- 20.) The screen will display "Span (corresponding number)".
- 21.) Press Enter to reset the (corresponding number) to span and hold for approximately 1-3 seconds.
- 22.) The screen will display "ACCEPT?".
- 23.) Press Enter (You have now set the span point).
- 24.) The screen will display "Cal Lev 1?".
- 25.) Press and hold all three buttons simultaneously for 2-3 seconds to reset the unit.
- 26.) The zero (4mA) and span (20mA) set points are now configured.

To calibrate or change the working range of the transmitter, press any button to enter Function Mode. Hit the enter button when the "CAL LEV 1?" prompt appears. "Calibrate Zero" should now be on the display, if not press the Up or Down button until it is. Press the enter button to set the low level of the range. At this time, position the float magnet at the desired low level point and keep it there while pressing the Enter button and holding it down for approximately two seconds. Once done, "ACCEPT" should be on the display, press the Enter button. This is now your new low level for the range.

Setting a new low level for the range does not change the high level position. To change the high level position, press Enter when "CAL LEVEL 1?" appears on the display. Press Enter again when "Calibrate Span" is displayed, using the Up and Down buttons if needed. Repeat the above steps beginning with "position the float magnet" to change the high level of the range. When done, press all three buttons to exit Function Mode.

## 8. ALARM SETTINGS

When a fault condition is detected by the internal microprocessor, the 4 to 20 mA current will go to the current selected.

In the 4 mA alarm mode, when a fault is detected the output will be continuous at  $3.8 \pm 0.1$  mA. In the 20 mA alarm mode, when a fault is detected the output will be continuous at  $21.5 \pm 0.2$  mA.

## 9. SPARE PARTS

MTI4200 Transmitter (Puck) P/N: **V19962HP**  
MTI4200 I/O PCB P/N: **V19962**