

JERGUSON®

A Division Of The Clark-Reliance Corporation

Specialists in Liquid Level Indication

Installation, Operation and Maintenance for

Top Mount Displacer Operated

Magnetic Level Switch

Section: JS100
Bulletin: JS100.05
Date: 10/1/04



FEATURES

- Tri-Magnet Switching
- Vibration Resistant
- Pump Control
- Multi-Point Alarm
- T316 SST Trim

APPLICATION

Jerguson displacer operated switches are ideal for sump and other top mounted applications such as low level alarm in deep tanks. Their principle of operation also makes them suitable in a modified form, for very high pressure or low S.G. applications.

The four typical displacer arrangements shown in the model selection guide cover the most common applications. However, should you have a special configuration requirement, please consult the factory.

OPERATION

The displacer element is suspended on a stainless steel cable attached to a spring. The displacer is always heavier than its equivalent volume of the liquid in which it is to operate, and therefore will always extend the tension spring. Hanging freely in the air, the spring extends to a predetermined length, limited by a mechanical stop to prevent overstressing. Attached to the spring is the magnet assembly which is free to move up or down as the spring extends or contracts.

As rising liquid submerges the displacer, a buoyant force is created equal to the weight of the displaced liquid volume. This buoyancy force reduces the apparent displacer weight, contracting the spring, and moves the magnet upwards inside the pressure tube actuating the switch mechanism. This simple principle also operates a single switch over a very wide differential by simply providing the buoyancy force from two displacers instead of a single displacer.

Two switch models are available for either two alarm applications, two narrow differentials, or for pump control with appropriate wide differentials. All models are fully field adjustable by simple re-setting the displacers on the cable "at the desired switch actuation point.



JERGUSON® GAGE AND VALVE

A Division of The Clark • Reliance® Corporation
16633 Foltz Industrial Parkway • Strongsville, OH 44149 USA
Telephone: (440) 572-1500 • Fax: (440) 238-8828

ORDERING INFORMATION

INTERNAL MOUNT DISPLACER TYPES

CODE	Function-Differential	Displacer	SPDT*	DPDT*	Tolerance
JDC1D	Single Switch-Narrow	316-SST	.50 - 1.2	.50 - 1.2	N/A
JDC4D	Single Switch-Narrow	Porcelain	.50 - 1.2	.50 - 1.2	N/A
JDC2D	Single Switch-Wide	316-SST	.50 - 1.2	.50 - 1.2	±10%
JDC5D	Single Switch-Wide	Porcelain	.50 - 1.2	.50 - 1.2	±10%
JDC3D	Duel Switch-Wide	316-SST	.60 - 1.2	.80 - 1.2	±5%
JDC6D	Duel Switch-Wide	Porcelain	.60 - 1.2	.80 - 1.2	±5%
JDC8D	Duel Switch-Narrow	316-SST	.60 - 1.2	.80 - 1.2	±10%
JDC9D	Duel Switch-Narrow	Porcelain	.60 - 1.2	.80 - 1.2	±10%

*Each unit is calibrated to operate at the specified S.G. within listed ranges.

ENCLOSURE TYPES

Duty	Material of cover	Material of base	Material of pressure tube	Material of screwed union	Maximum number of switches
SA7 Explosion-proof	Aluminum Alloy	Aluminum Alloy	316 Stainless Steel	To match chamber material	2 x four contact or 2 x eight contact
S17 Weather-proof	Cast Iron	Aluminum Alloy	Steel		



INTERNATIONAL APPROVALS

U	Underwriters Laboratories	Cl. I, Div. 1, Grp. C & D
C	Canadian Standards Association	Cl. I, Div. 1, Grp. C & D
B	BASEEFA/CENELEC	E Exd IIC T6; BS5501: Pts 1 & 5
H	Underwriters Laboratories	Cl. I, Div. 1, Grp. B, C & D
N	Weatherproof to NEMA 4X/IP66	U.L. CSA EANSW

NUMBER OF SWITCH MECHANISMS

Refer to Displacer Function for No. of Switches

SWITCH MECHANISM TYPES

	Temp Wet-side °F	AC max. values		DC max. values				
		VA	Volts	Amps	Watts	Volts	Res. Amps	Ind. Amps
D4 X4 H4 P4 4 Contact  Link for SPDT single throw contact sets	750	2000	440	5	50	250	5	0.5
	480	2000	440	10	50	250	10	0.5
	480	2000	440	10	50	250	10	0.5
	750	6	250	0.25	3.6	250	0.25	0.1
D8 X8 H8 P8 8 Contact  Link for DPDT single throw contact sets	750	2000	440	5	50	250	5	0.5
	480	2000	440	10	50	250	10	0.5
	480	2000	440	10	50	250	10	0.5
	750	6	250	0.25	3.6	250	0.25	0.1

TYPICAL MODEL

JDC 2D SA4 N 1 X4 / 60

Displacer



Enclosure

Approval

No. of Switches

Switch Mechanism

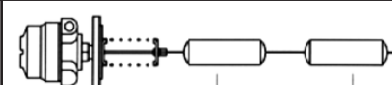
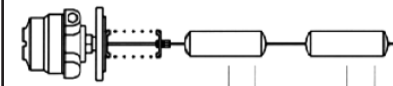
MOUNTING CONNECTION - MATERIAL OF CONSTRUCTION

MODEL JDC - CARBON STEEL	MODEL JDS - 316 SST
DISPLACER FUNCTIONS	
<p>Single switch narrow differential: 1D, 4D.</p> <p>Specify for alarm duty, bi level or lo level.</p> <p>Switching level can be changed by simply moving the displacer up or down the cable.</p> <p>SST CABLE 10 FT. LONG</p> <p>NARROW DIFFERENTIAL</p> 	<p>Single switch wide differential: 2D, 5D.</p> <p>The two displacer elements are positioned at any point on the cable to correspond to the switching levels required. When the liquid level drops to the lower displacer, a switch is actuated and starts (or stops) a pump, when the liquid rises to the upper displacer, the switch is again actuated to stop (or start) the pump.</p> <p>WIDE DIFFERENTIAL</p> 
<p>Two switch 2 narrow differentials: 8D, 9D.</p> <p>The displacers are positioned to form two elements of similar lengths, such that two alarm points may be given. This arrangement is typical of sump application.</p> <p>UPPER SWITCH</p> <p>LOWER SWITCH</p> 	<p>Two switch 2 wide differentials: 3D, 6D.</p> <p>A pump is controlled between the middle and the lower displacers positioned on the cable at the required levels. Should the level rise to the upper displacer, this actuates the upper alarm switch which remains actuated until the level drops to the middle displacer. Alternatively the upper switch could control a second pump.</p> <p>UPPER SWITCH</p> <p>LOWER SWITCH</p> 

NOTE: All models supplied with 10 ft. long SST Cable as Standard.

MOUNTING CONNECTION

CODE	SIZE	CARBON STEEL RATING	SST RATING
60	3" 150# R.F. ANSI	285 PSIG @ 100°F	275 PSIG @ 100°F
61	3" 300# R.F. ANSI	740 PSIG @ 100°F	720 PSIG @ 100°F
62	3" 600# R.F. ANSI	1480 PSIG @ 100°F	1400 PSIG @ 100°F
65	4" 150# R.F. ANSI	285 PSIG @ 100°F	275 PSIG @ 100°F
66	4" 300# R.F. ANSI	740 PSIG @ 100°F	720 PSIG @ 100°F
67	4" 600# R.F. ANSI	1480 PSIG @ 100°F	1400 PSIG @ 100°F
69	6" 150# R.F. ANSI	285 PSIG @ 100°F	275 PSIG @ 100°F
80	2 1/2" NPT	1000 PSIG @ 100°F	1000 PSIG @ 100°F
90	3" NPT	1000 PSIG @ 100°F	1000 PSIG @ 100°F

DIMENSIONAL AND OPERATING LEVEL DATA

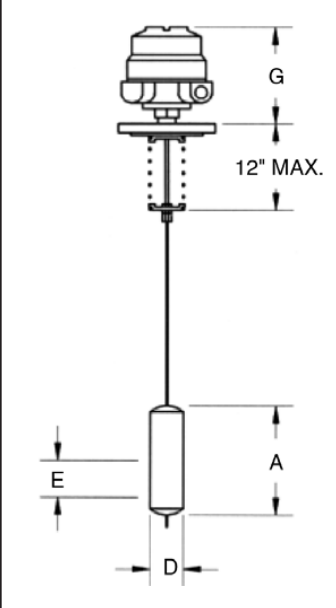
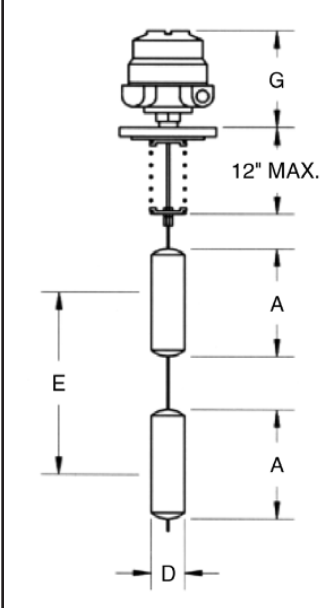
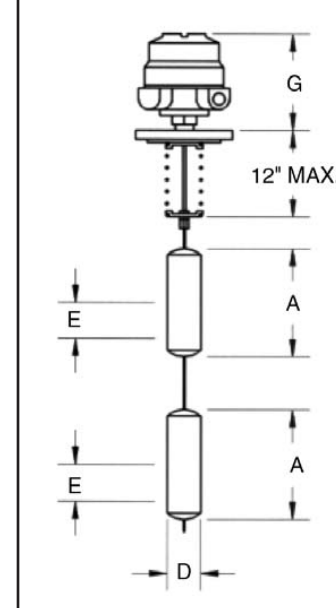
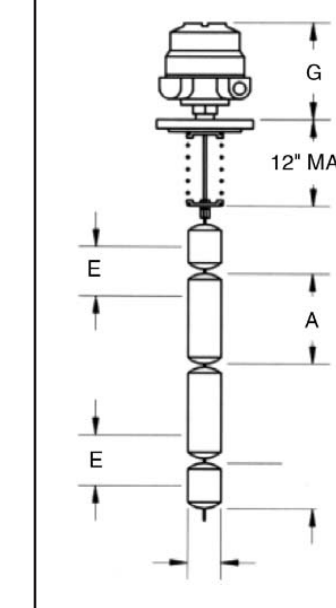
			
ID SST: A = 7 1/2 D = 2 1/2	2D SST: A = 7 1/2 D = 2 1/2	8D SST: A = 7 1/2 D = 2 1/2	3D SST: A = 7 1/2 B = 4 D = 2 1/2
S.G. 0.50 0.60 0.80 1.00	S.G. 0.50 0.60 0.80 1.00	S.G. 0.80 0.90 1.00 1.10	S.G. 0.80 0.90 1.00 1.10
E min. 3 1/2" 3" 2 1/2" 2"	E min. 7 1/4" 6 1/4" 5 1/4" 4 5/8"	E min. 2 1/2" 2 1/4" 2" 1 7/8"	E min. 5" 4 3/4" 4 1/2" 4 1/4"
4D Porcelain: A = 7 3/4 D = 2 9/16	5D Porcelain: A = 7 3/4 D = 2 9/16	9D Porcelain: A = 9 1/2 D = 2 9/16	6D Porcelain: A = 7 3/4 B = 3 7/8 D = 2 9/16
S.G. 0.50 0.60 0.80 1.00	S.G. 0.50 0.60 0.80 1.00	S.G. 0.80 0.90 1.00 1.10	S.G. 0.80 0.90 1.00 1.10
E min. 3 5/8" 3" 2 3/8" 2"	E min. 7 1/4" 6 5/8" 5 1/2" 5"	E min. 3 1/2" 3 1/4" 3" 2 3/4"	E min. 4 7/8" 4 1/2" 4 1/4" 4"

E min. = Differential

ENCLOSURE DIMENSIONAL DATA

Type	Duty	Height G	Conduit Thread	Weatherproof Rating
SA7, S17	Explosionproof	13 3/4"	1" NPT	NEMA 4x & 7
SA4	Weatherproof	12"	1" NPT	NEMA 4x

MATERIALS OF CONSTRUCTION

Technical Specification	Model JDC	Model JDS
Materials of Construction	Carbon Steel Chamber	Stainless Steel Chamber
Pressure Tube	ASTM A312 T316	ASTM A312 T316
Pressure Tube Fitting	1018 C.S.	T316 LSST
Flange	ASTM A105	ASTM A182 F316
Displacer	As specified	As specified
Spring	Iconel 625	Iconel 625
Trim	T316 SST	T316 SST

Options:

- Low temperature carbon steel chambers • Controls to meet N.A.C.E. requirements • A comprehensive N.D.T. package

WARRANTY STATEMENT

All Jerguson® mechanical level devices are warranted free of defects in materials and workmanship for five years from the date of original factory shipment.

If returned within the stated warranty period; and upon factory inspection the cause of the claim is determined to be covered under the warranty: at Jerguson's option,

the device will be repaired or replaced without cost to the purchaser (or owner) other than transportation.

Jerguson shall not be liable for mis-application, labor claims, direct or consequential damage or expense arising from the installation or use of the equipment. There are no other warranties expressed or implied.

**5 YEAR
MECHANICAL
WARRANTY**

JERGUSON LEVEL SWITCHES THE SWITCH MECHANISM

Principle of Operation

The switch mechanism is based on a unique three-dimensional magnet design where the snap action is accomplished by the utilization of magnetic repulsion. The magnet mounted on the float rod causes the secondary magnet to rotate as it passes up and down. The switch magnet is repelled by the secondary and snaps to the opposite side. This causes the cradle to pivot, moving the push rods which operated the switch contacts. The result is positive snap action interlock switching...**no springs...no spring problems.**

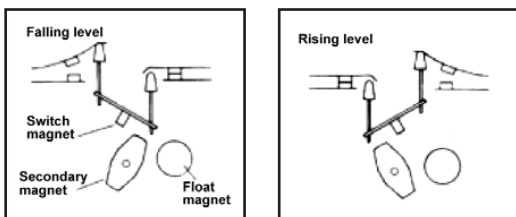

Schematic showing three-magnet system

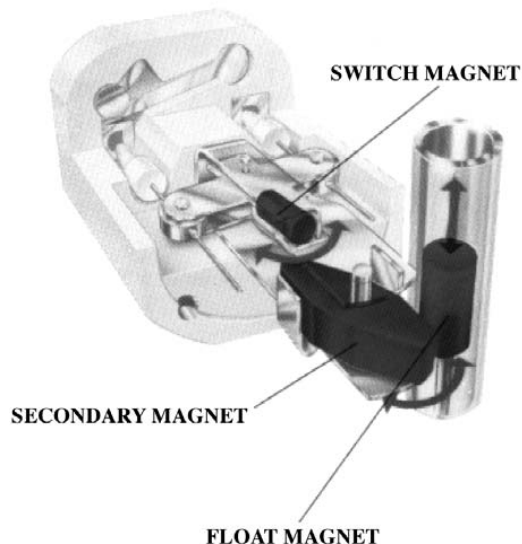

Choice of Switch Mechanisms	
Type	Application
X4, X8	General purpose – 10 amp mechanisms for general purpose duties up to 480°F
D4, D8	High temperature – 750°F mechanisms for high temperature applications up to 5 amps
H4, H8	Hermetically sealed – Suitable for low temperature duties, contaminated atmosphere environments and intrinsically safe circuits. All moving parts and contacts enclosed in an inert gas filled stainless steel enclosure.
P4, P8	Low current – Gold-plated contact switch mechanism for use in intrinsically safe or low power circuits up to 750°F

4 Contact Type D4, X4, P4, H4	
2 x S.P.S.T. AA Make on Rise BB Make on Fall	
Link for SPDT/SPCO	
8 Contact Type D8, X8, P8, H8	
D.P.D.T. 4 x S.P.S.T. AA Make on Rise BB Make on Fall	
Link for DPDT/DPCO	

PRINCIPLE OF OPERATION

The displacer element, made of either stainless steel or ceramic depending upon the application, is suspended on a stainless steel cable from a spring. The displacer element is always heavier than its equivalent volume of the liquid in which it is to operate, and therefore will extend the tension spring at all times. Hanging freely, the spring will extend to a known length, controlled by a mechanical stop to prevent overstressing. Attached to the spring is the rod and magnet assembly, which is free to move up and down within the pressure tube as the spring extends or contracts, actuating the switch mechanism.

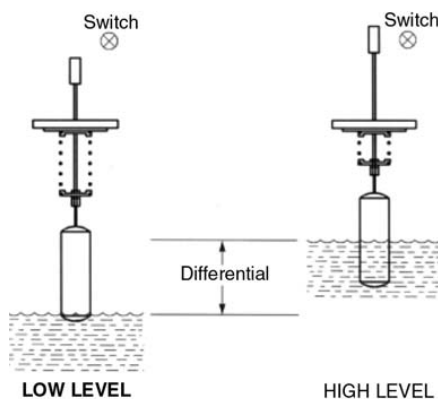

This simple principle can be refined to operate a single switch over a very wide differential by providing the buoyancy force from two displacer elements instead of a single one.

Two switch models are available for two applications with two narrow differentials for pump control with appropriate wide differentials.

In all cases, because the elements are suspended on a cable, switching or control levels may be many feet below the mounting flange, and are fully field adjustable to re-setting the displacer elements on the cable.

As rising liquid submerges the displacer, a buoyancy force is created equal to the weight of the displaced liquid volume. This force reduces the apparent weight of the displacer, contracting the spring and moving it upwards inside the pressure tube, actuating the switch mechanism. On a falling liquid level, the displacer element is uncovered and the spring senses an increasing effective weight, extending the spring. The increased effective weight moves the magnet to re-set the switch mechanism.

JERGUSON "FIT & FORGET" PRODUCTS PROVIDE THE SOLUTION TO YOUR LIQUID LEVEL CONTROL PROBLEMS

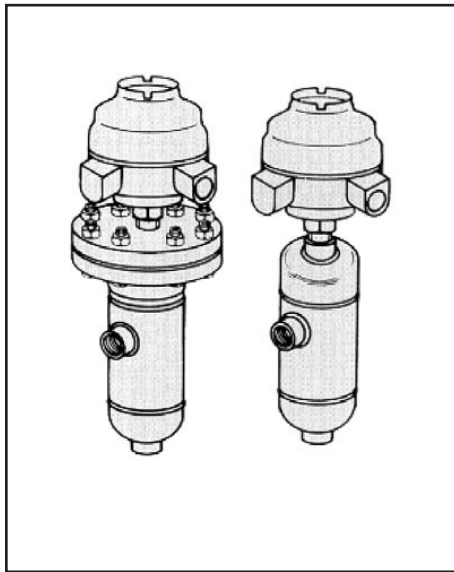

Medium Pressures
ANSI Class 150, 300, 600
SG 0.40

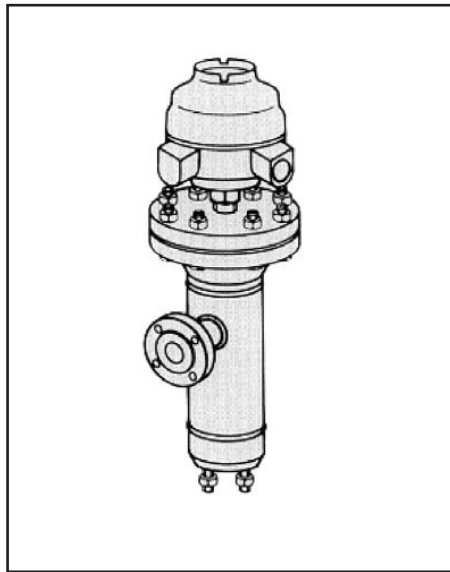

High Pressures
ANSI Class 900, 1500, 2500
SG 0.40

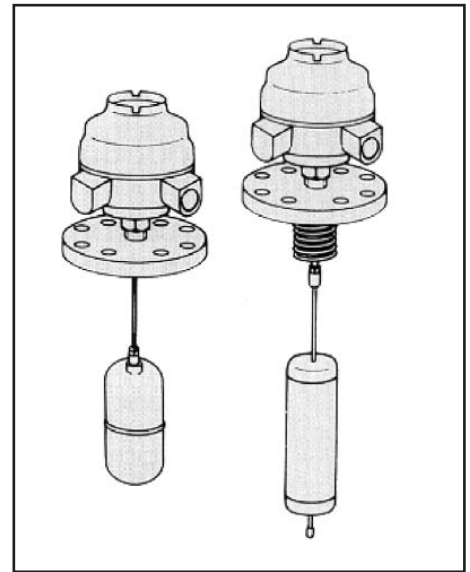

Direct Mounting
ANSI Class 150, 300, 600
SG 0.40

You can rely on us

The Jerguson range of liquid level controls is designed for operation in a wide variety of applications

Typical Applications

Separators	Water Sumps
Compressors	Scrubbers
Knock-out Pots	Fractioning Columns
Condensers	Process Vessels
De-actuators	Condensate Tanks
Storage Tanks	Drainpots
Service Tanks	Accumulators
Header Tanks	Flash Vessels
Effluent Sumps & Tanks	Fuel Tanks
Heat Exchanger	Feedwater Heaters
Lube Oil Tanks	Surge Drums

Jerguson level switches are used for the control of liquids by companies all over the world.

Shell	Bechtel
Exxon	Bellili
Amoco	Ontario Hydro
Fluor	Nissaci-Sangyo
Hyundai	Foster Wheeler
Hitachi	Siemens
British Petroleum	Mannesmann-Demag
Mobil	Catalytic
Texaco	Techni
Ingersoll Rand	Technipetrol
Compair	Nuovo Pignone
Honeywell	Dresser



JERGUSON® GAGE AND VALVE

A Division of The Clark • Reliance® Corporation
16633 Foltz Industrial Parkway • Strongsville, OH 44149 USA
Telephone: (440) 572-1500 • Fax: (440) 238-8828