

*process measurement solutions*

# MAGNE-SONIC

Operation Installation &  
Maintenance of Vertical Controls

Instruction leaflet



Series B



Series X



Series D

# M vertical magnetic level controls

## Principle of Operation

Switching is achieved with the “three-magnet” system, giving snap-action “latch-on” switching.

Vertical movement of the primary magnet A in a glandless pressure tube simultaneously actuates magnets B & C to switch the contacts. The “three-magnet” system enables the primary magnet to pass on and actuate switch mechanisms at other levels. Switch mechanisms already actuated can not re-set until the return of the primary magnet actuates the magnet system once again.

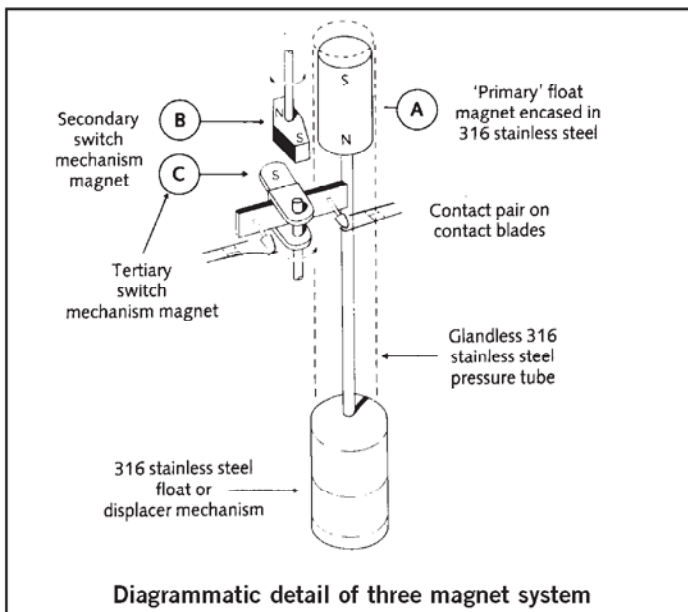

The primary magnet is moved vertically in the pressure tube by a float or displacer mechanism which rises and falls with the liquid level.

## Identifying your control

This manual covers the three series of controls : B, X and D as shown opposite. Your control has a part number stamped on the nameplate, an example of which is shown below. From this number you can identify your control and turn to the relevant pages in this manual.

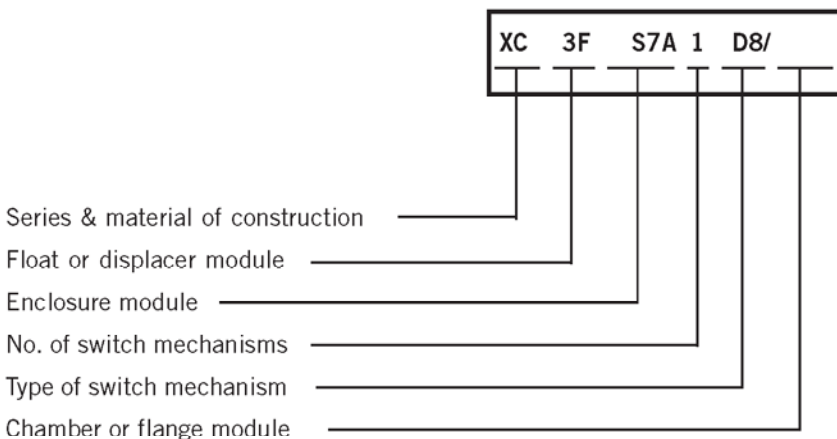

# Electrical characteristics

## 4 Contact Type : D4, X4, P4, H4



2 x independent SPST  
AA make on rise: BB Make on fall

## 8 Contact Type : D8, X8, P8, H8



Double pole double throw  
(4 x independent SPST)  
AA make on rise, BB make on fall

**Note :** For DPDT operation, installer must common any one pair of A and B wires in the terminal block for each of the two ends of the switch mechanism.

### Wiring Examples

#### Single-switch Control

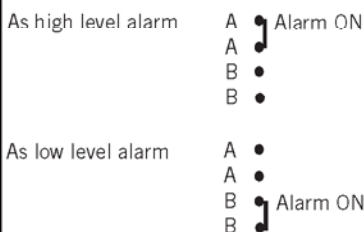

#### Two-switch Control Combined Pump Control and Low Level Alarm

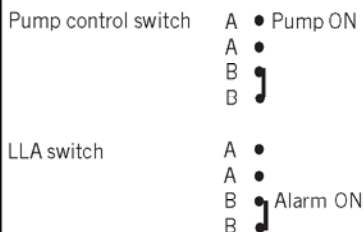

#### Two-switch Control High and Low Level Alarm

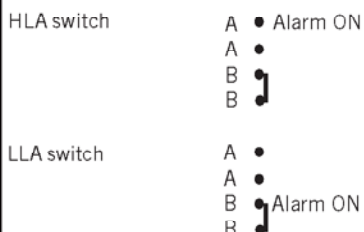

Each switch mechanism has flying leads which are factory wired to ceramic terminal blocks fixed in the switch enclosure.

### Electrical Rating

Type	Temp wetside °C	Low temp use	AC max. values			DC max. values			
			VA	Volts	Amps	Watts	Volts	Res amps	Ind amps
D4, D8	400	Amb.	2000	440	5	50	250	5	0.5
X4, X8	250	Amb.	2000	440	10	50	250	10	0.5
P4, P8	400	Amb.	6	250	0.25	3.6	250	0.25	0.1
H4, H8	250	-100°C	2000	440	10	50	250	10	0.5
Power factor 0.4min						Time constant 40ms max.			

### Warning

Gold plating on the contacts of the P4 and P8 switch mechanisms may be permanently damaged if the mechanisms are used to switch circuits with values greater than those shown above.

### Important Wiring Notes

- Switches must not be used for the direct starting of motors. Contacts should be wired in series with the operating coils of relays, contactor starters or solenoid valves, and fused separately.
- The temperature of the switch enclosure may at times approach the temperature of the process and suitable heat resisting cables should therefore be used, together with appropriate cable glands.
- A sufficient length of flexible cable should be fitted to allow easy removal of the switch head and float assembly at any time.

### Flameproof models

- Cable entry must be fitted with a flameproof cable entry device, with or without thread adaptor, approved by BASEEFA for IIC enclosures and which, together with the cable, are suitable for the conditions of use according to Code of Practice BS5345:Pt 1979 or equivalent. For non- U.K. installations, cable entry devices suitably approved by other approval authorities which equally maintain the integrity of the flameproof enclosure by providing a minimum of 5 threads engagement as required by EN 50018, may be used in accordance with a local Code of Practice subject to agreement by the local Inspecting Authority.

- U.L. Approved Applications; Use copper conductors 60°/75°C: 140°/167° ONLY. Torque terminals to 6Kg/cm: 7lb/in.

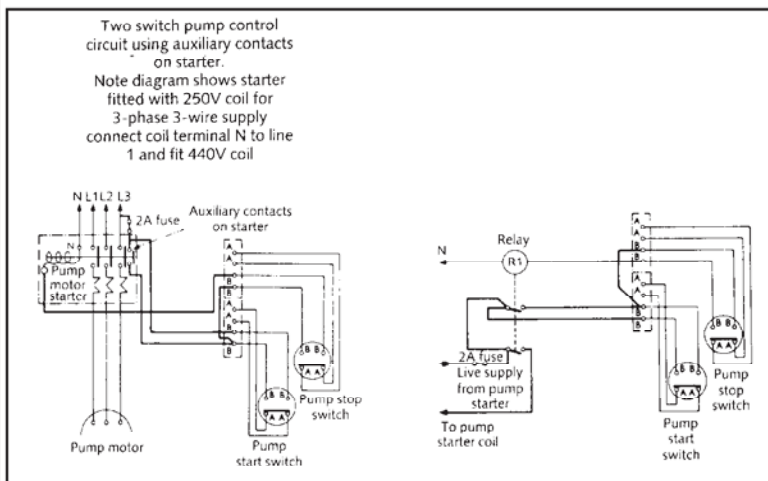

# Series B & X

## Installation Instructions

When installing, using or maintaining external chambers supplied compliant with the Pressure Equipment Directive, refer also to the Safety Information supplied with the product for further

1. Remove all sealing tapes, tie strings and packing from the control prior to installation.
2. Mount the control on the inlet and outlet connections, ensuring that the central line axis of the control is vertical to the eye. Use suitable process connection gaskets and seals as dictated by the application.
3. Check bolt torques on process and switch head flange bolts are in accordance with torques shown.

### Note

- i) A 50mm weld bead or label on the chamber indicates the highest operating level of the control. Switch point adjustment of 100mm is provided on multi-switch models only and is measured down from this level.
  - ii) Allow at least 200mm above the control for removal of cover.
3. Remove switch head cover to reveal terminal block(s) to which electrical connections are to be made. Flameproof models : Locate and slacken off M5 socket head grub screw in side of cover adjacent to base joint. Place a bar across the top of the cover, locating in the castellations. The cover can now be unscrewed from the base using the bar as a lever.  
Weatherproof models: The cover can be removed by unscrewing the single hexagon nut at the crown of the cover.
4. Connect electrical wiring via the conduit entries using a suitable cable gland. Note that the base of the enclosure is rotatable on the pressure tube to allow the most convenient orientation of the conduit entry.

On models with flameproof enclosures type ★7★ the switch mechanism may be raised on the pressure tube to ease access to the terminal block. Ensure that the switch mechanism is re-positioned to its lowest position (i.e. sitting on the limit tube around the pressure tube) after wiring.

5. Switch point adjustments may now be made if necessary. See below.
6. The lugs of the tab washer directly underneath the base must now be bent over to locate on the most appropriate flats of the hexagon union. This prevents further rotation of the switch head, and is particularly important as it will prevent rotation when the cover is removed or re-fitted.
7. Replace cover, ensuring cover seals are in position. Ensure cover locking grub screw is replaced and tightened on flameproof models. The fibre sealing washer at the crown nut of the weatherproof cover must be re-fitted to maintain weatherproof seal.

### Switching Point Adjustment

Each switch mechanism is mounted on a bracket, which is secured on the pressure tube by a locking screw and lock nut. These can be loosened, allowing the bracket to be adjusted up or down as required. Always ensure that the small pressure plate between the locking screw and the pressure tube is in place before re-tightening the locking screw nut.

**Important note:** Switches can not be adjusted outside of the range set by the stops on the pressure tube. Displacer operated control type ★★7D are single switch models with the switching point factory set. There is *no* site adjustment.

	Enclosure Type	Switch Mechanism Type		
		D4, P4, X4	H4	D8, P8, X8, H8
Max No. Switches	R7A	1	1	1
Sw. Adjustment 'B' mm	R7I	7	7	7
Max. Wet switching differential	R4N	Type 1F, 2F, 3F, 4F : 20mm Type 7D : See table above (D-C)		
Max. No. Switches	S7A S7I S4N	4	4	2
Sw. Adjustment 'B' mm		100	100	100
Max. Sw Crs 'B' mm		100	100	100
Min. Sw Crs 'B' mm		7	0	56
Max. Wet switching differential		Type 1F, 2F, 3F, 4F : 120mm		

# Operating Level Data

Models Type No. B★1F, B★2F, B★3F, B★4F, B★7D, X★1F, X★2F, X★3F, X★4F, X★7D

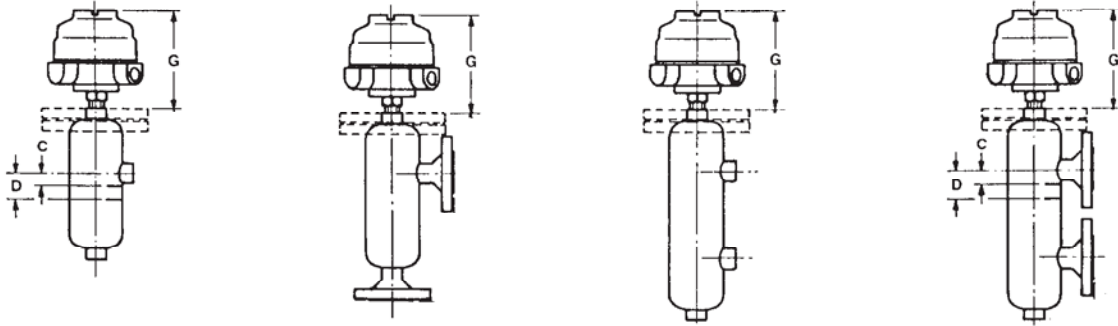

C = Highest Operating Liquid Level  
D (Single Switch) = Reset Level

D (Multi-Switch) = Lowest Operating Liquid Level  
D-C = Wet Switching Differential (Max)

### Operating Levels : Single switch models

Min Operating S.G.	1F : 0.80	2F : 0.75	3F : 0.65	4F : 0.54
Dimension C	50	50	50	50
Dimension D	70	70	70	70

### Operating Levels : Multi-switch models

Min Operating S.G.	1F : 0.80	2F : 0.75	3F : 0.65	4F : 0.54
Dimension C	50	50	50	50
Dimension D	170	170	170	170

### Operating Levels : Type 7D float in any chamber : Single switch only

Min Operating S.G.	0.4	0.5	0.6	0.7	0.8	0.9	1.0	1.1	1.2
Dimension C	65	73	82	91	100	109	118	127	136
Dimension D	118	122	127	132	137	141	147	152	156

### Dimensional Data : Enclosures

Type	Duty	Height G	Conduit Thread	Switch Adjustment	Weatherproof Rating
R 7, RI7	Flameproof	190	1" NPT	10	(NFMA 7)
S 7, SI7		300		100	(NEMA 4)
R 4	Weatherproof	170	1" NPT	10	(NEMA 7)
S 4		275		100	(NEMA 4)

Enclosures for use with 8 contact switch mechanisms have both conduit entries threaded, whilst those for use with 4 contact switch mechanisms have only one entry.

# Series D

## Installation Instructions

1. Remove all sealing tapes, tie strings and protective packings from the control prior to installation.

If float rod length needs adjusting to allow a higher operating level, refer to adjustment notes.

**Note:** Careful handling is required at all times to ensure float and float rod are not damaged or bent.

If a control is fitted with a longer than standard rod (i.e. dimension H is greater than that shown in the adjoining table) or the liquid is subject to excessive turbulence or agitation, then a stilling tube should be fitted.

2. If control has been ordered without a mounting flange, the float unit must be removed from the control before the switch head can be mounted on the vessel via the 1" NPT threaded boss provided. This is achieved by locating the Stop Assembly at the base of the 1" NPT threaded boss and easing the spring clip, allowing the entire float assembly to be removed.

3. Mount the switch head on the vessel using the flange (if provided) or the 1" NPT threaded boss ensuring that the centre line axis is vertical to the eye. If the threaded boss is used, ensure a pressure tight seal is formed between it and the vessel. Use only the hexagonal boss to tighten the 1" NPT thread into the mounting boss or flange. Torque flange bolts in accordance with torques shown.

4. Ensure that magnet is free from swarf and debris before re-fitting to switch head. Locate the two ends of the spring clip in the two cross holes in the base of the pressure tube ensuring that float assembly is free to move vertically and is securely retained by the Stop Assembly.

5. Remove switch head cover to reveal terminal block(s) to which electrical connections are to be made:-

Flameproof models: Locate and slacken off M5 socket head grub screw inside of cover adjacent to base joint. Place a bar across the top of the cover, locating in the castellations. The cover can now be unscrewed from the base using the bar as a lever.

Weatherproof models: The cover can be removed by unscrewing the single hexagon nut at the crown of the cover.

6. Connect electrical wiring via the conduit entries using a suitable cable gland. Note that the base of the enclosure is rotatable on the pressure tube to allow the most convenient orientation of the conduit entry.

**Weatherproof enclosure**

Float	ØZ	H
1F	67	330
2F	90	430
3F	88	430
4F	88	430

If float rod length needs adjusting to give a higher operating level, refer to adjustment notes.

**Weatherproof enclosure**

Float	ØZ	H
1F	67	330
2F	90	430
3F	88	430
4F	88	430

If float rod length needs adjusting to give a higher operating level, refer to adjustment notes.

Operating Levels	
Lowest Operating Level	H + 35
Highest Operating Level : see adjustment notes	(H + 35) - (B + 20) where B is the max. switch adjustment from table on page 8.

On models with flameproof enclosures type ★7★ the switch mechanism may be raised on the pressure tube to ease access to the Terminal Block. Ensure that the switch mechanism is re-positioned to its lowest position (i.e. sitting on the limit tube around the pressure tube) after wiring.

7. Switch point adjustment may now be made if necessary.

8. The lugs of the tab washer directly underneath the base must now be bent over to locate on the most appropriate flats of the hexagon union. This prevents further rotation of the switch head, and is particularly important as it will prevent rotation when the cover is removed or re-fitted.

9. Replace cover, ensuring cover seals are in position. Ensure cover locking grub screw is replaced and tightened on flameproof models. The fibre washer at the crown nut of the weatherproof cover must be re-fitted to maintain weatherproof seal.

### Switching Point Adjustment

Each switch mechanism is mounted on a bracket, which is secured on the pressure tube by a locking screw and lock nut.

These can be loosened, allowing the bracket to be adjusted up or down as required. Always ensure that the small pressure plate between the locking screw and pressure tube is in place before re-tightening the locking screw nut.

**Important note:** Switches can not be adjusted outside of the range set by the stops on the pressure tube.

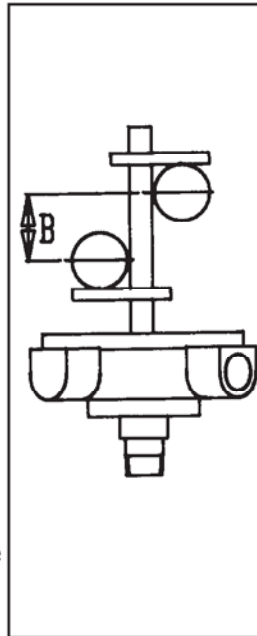

Enclosure Type	Switch Mechanism Type		
	D4, P4, X4	H4	D8, P8, X8, H8
Max. No. Switches	1	1	1
Sw. Adjustment 'B'	7	7	7
Max. Wet switching differential	Type 1F, 2F, 3F, 4F : 20mm		
Max. No. Switches	4	4	2
Sw. Adjustment 'B'	100	100	100
Max. Sw Crs 'B'	100	100	100
Min. Sw Crs 'B'	7	0	56
Max. Wet switching differential	Type 1F, 2F, 3F, 4F : 125mm		
Max. No. Switches	6	6	3
Sw. Adjustment 'B'	200	200	200
Max. Sw Crs 'B' in	200	200	200
Min. Sw Crs 'B'	7	0	56
Max. Wet switching differential	Type 1F, 2F, 3F, 4F : 9"		

### Float Rod Length Adjustment

The highest operating level given by the float rod as supplied can be made higher (i.e. nearer the mounting point) by shortening the float rod on site, as follows:

Remove float unit from control by locating the Stop Assembly in the base of the 1" NPT threaded boss and easing the spring clip out of the two locating holes in the pressure tube. The rod and the magnet assembly can now be withdrawn from the pressure tube. Undo the hexagonal float adaptor to remove the float from the rod, and slide the adaptor up the rod. Hacksaw the stainless steel rod to the required length according to the diagram below, then re-clench the rod end in a vice as shown. Re-fit the float, ensuring the spring washer is used between float and adaptor.

Re-fit the float unit to the switch head, ensuring that the magnet is free from swarf and debris. Locate the two ends of the spring clip in the two cross holes in the pressure tube; ensuring that the rod and magnet assembly are free to move vertically in the pressure tube and that it is securely retained by the Stop Assembly.

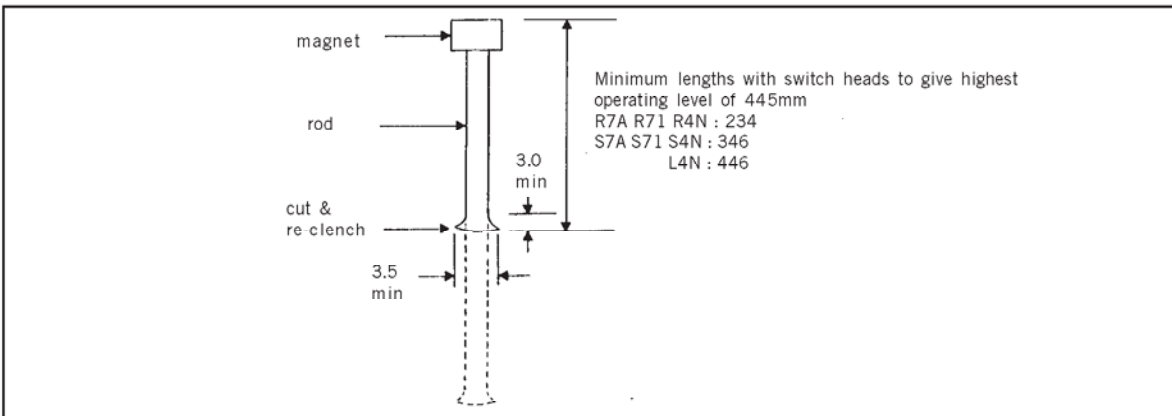

# Maintenance of the vertical level controls

## Series B-Vertical Integral Type

This type of control is of the 'sealed chamber' type and the float or displacer mechanism cannot be removed. However, the switch mechanisms and switch head should be visually checked periodically.

1. Isolate electrical circuits to control and disconnect wiring as necessary.
2. Remove the switch head cover and examine the switch mechanism body for any damage. Ensure that wiring is in good order and that all the screws are tight. **Dismantling of switch unit is not recommended and replacement of the complete switch unit will be found to offer the quickest and most economical solution in event of faulty operation.**
3. Check sealing gasket / "O" ring and replace if necessary.
4. Re-connect electrical supply and replace cover, ensuring cover seals are in position. Ensure cover locking grub screw is replaced and tightened on flameproof models. The fibre washer at the crown nut of the weatherproof cover must be re-fitted to maintain weatherproof seal.

## Series X - Vertical Flanged Type

This type of control is flanged between the switch head and chamber such that the float may be withdrawn and removed from the chamber for inspection.

- 1 Isolate electrical circuits to control and disconnect wiring as necessary.
- 2 Isolate the chamber from the pressure vessel by closing the isolation valves, and open the valve of the drain connection.
3. Remove nuts holding control to chamber, carefully withdraw switch head and float assembly, taking care not to bend the float rod.
- 4 Separate float assembly from switch head by removing stop clip.
- 5 Inspect the chamber and remove any deposits.
- 6 Check float, float rod and magnet for excessive wear, clean and replace as necessary.
- 7 Fit replacement joint and reassemble, taking care not to bend the float rod. Firmly tighten nuts on top flange, using bolt torque values given in tables.
- 8 Remove the switch head cover and examine the switch mechanism body for any damage. Ensure that wiring is in good order and that all the screws are tight. **Dismantling of switch units is not recommended and replacement of the complete switch unit will be found to offer the quickest and most economical solution in event of faulty operation.**
- 9 Check sealing gaskets / "O" ring and replace if necessary.
- 10 Reconnect electrical supply and replace cover, ensuring cover seals are in position. Ensure cover locking grub screw is replaced and tightened on flameproof models. The fibre washer at the crown nut of the weatherproof cover must be re-fitted to maintain weatherproof seal.
- 11 Close drain valve connection, open isolating valves and check that the control is operating at the correct levels.

## Series D - Direct Mounted Type

This type of control is mounted directly onto the process vessel, or may be mounted in a chamber.

- 1 Isolate electrical circuits to control and disconnect wiring as necessary.
- 2 Ensure the vessel is vented to atmosphere, or isolate any chamber from the vessel by closing the isolating valves, and open the valve of the drain connection.
- 3 Remove nuts holding control to chamber or vessel. Carefully withdraw switch head and float assembly, taking care not to bend the float rod.
- 4 Separate float assembly from switch head by removing stop clip.
- 5 Inspect the chamber or stilling tube and remove any deposits.
- 6 Check float, float rod, and magnet for excessive wear, clean and replace as necessary.
- 7 Fit replacement joint and reassemble, taking care not to bend the float rod. Use bolt torque values given in tables on page 11.
- 8 Remove the switch head cover and examine the switch mechanism body for any damage. Ensure that the wiring is in good order and that all screws are tight. **Dismantling of switch units is not recommended and replacement of the complete switch unit will be found to offer the quickest and most economical solution in event of faulty operation.**
- 9 Check sealing gaskets / "O" ring and replace if necessary.
- 10 Re-connect electrical supply and replace cover, ensuring cover seals are in position. Ensure cover locking grub screw is replaced and tightened to flameproof models. The fibre washer at the crown nut of the weatherproof seal.
11. If the control is mounted into a chamber, close drain valve connection, open isolating valves and check that the control is operating at the correct levels.