

Specialists In Liquid Level Indication**70 & 70-L Series Valves**

Jerguson gage valves are simple, rugged instruments engineered and constructed throughout to give you accurate liquid level reading for the life of the vessel. With a complete range of models for any application, from pure water to highly corrosive chemical.

Like any instrument, Jerguson gage valves must be installed, operated and maintained with reasonable care and due regard for the application and environment.

INSPECTION AND DELIVERY

Upon receiving valves, check all components carefully for damage incurred in shipping. Confirm that valve model number and pressure temperature ratings (on nameplate) meet application specifications. Also confirm that the material is compatible with both process fluid and surrounding atmosphere for your application.

CAUTION: Jerguson gage valves are not to be used for gaging lethal substances as defined by ASME Section VIII.

BEFORE YOU INSTALL THE GAGE VALVES

- To avoid imposing piping strains on the valves, connect and mount the valves so that they do not support the piping.
- Support brackets should be considered, if level gage is over four feet in length or over 100 pounds in weight, especially when exposed to vibration. Support brackets will prevent overloading the valves.
- When installing liquid level gages, always provide shut off valves between gage and vessel. Jerguson automatic ball check valves are recommended to help provide protection against physical injury and loss of product if glass breakage should occur.

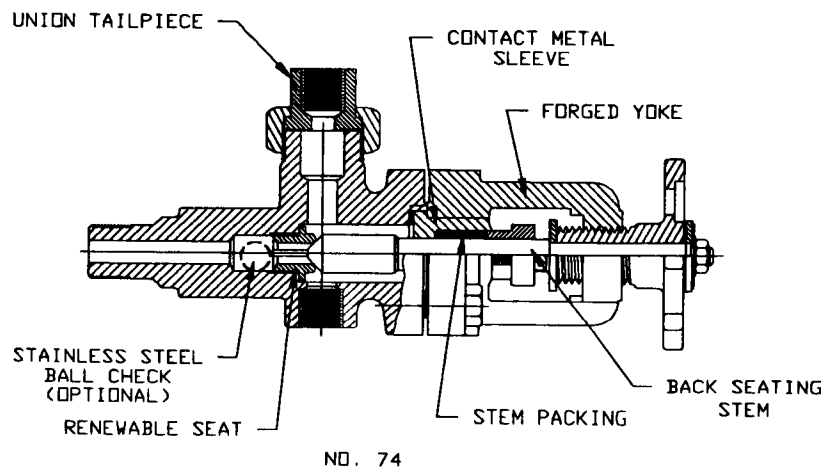
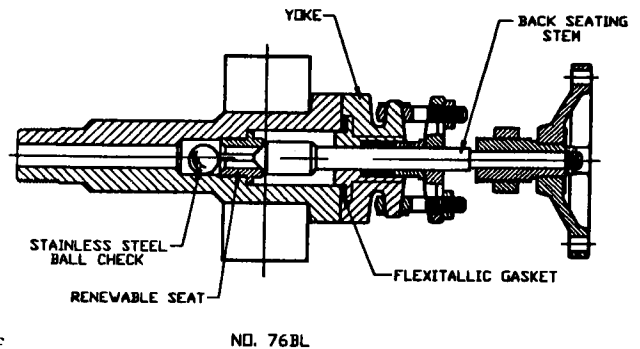

Installation, Operating and Maintenance Instructions • 70 & 70-L Series Valves

OPERATION

CAUTION: Rapid opening of valves can cause glass breakage and/or possible injury to personnel.

For protection during shipments, packing gland is loosened and stem is in the open position. Adjust stem and packing after installation. Do not tighten packing more than enough to stop leakage.

Crack open the valves carefully, and wait until equipment is fully warmed up and/or pressure is equalized before opening valves all the way.

CAUTION: While the valves are in operation, they must be in their fully open position. A partially open valve will prevent automatic ball checks from seating which could result in physical injury to personnel and loss of product.

MAINTENANCE

CAUTION: Prior to any disassembly of valves, first be sure that the valves are relieved of all internal pressure, and temperature is ambient, and has been drained and/or purged of any fluids. Failure to do this may result in a sudden release of pressure and/or physical injury to personnel.

CAUTION: When gage fails causing ball checks to seat, closing the valve will allow fluid to flow from vessel during that period when pin pushes ball off its seat and before stem has contacted seat, the operator could be hurt if not realizing what is happening or fires could result if hazardous liquids are involved.

TO REPLACE STEM PACKING

Close valves and drain fluid (70L Series). Remove packing gland nuts (70 Series). Remove packing gland cap screws, pull packing gland out of stuffing box. Remove old packing and install new packing. (Note: new packing should be installed by seating each ring individually. If seating of the complete pack of rings is done simultaneously, the ring nearest the gland will be overloaded and the bottom rings may do no sealing whatsoever). Packing ring joints should be staggered 90 degrees apart. Replace packing gland cap screws and/or nuts and tighten enough to stop leakage around stem without causing excessive binding on stem during operation.

TO REPLACE VALVE SEAT

Remove the yoke assembly and flexitallic gasket from the valve. Discard the flexitallic gasket. Using a standard 5/8" socket wrench remove seat. Before replacing seat apply lubricant (Molykote "G" or equivalent) to the threads to prevent seizure of metals. The seat is then replaced and tightened well to prevent leakage. Reassemble yoke assembly with new flexitallic gasket.

WARNING: During system shut down, it is best to leave shut off valves open, the equipment then cools and depressurizes along with the system. Keeping valves closed during shut down can trap high pressure liquid in the valves.



JERGUSON® GAGE AND VALVE

A Division of The Clark • Reliance® Corporation
13200 North Promenade • Stafford, TX 77477 USA
Telephone: (281) 240-4243 Fax: (281) 240-7299

JERGUSON® GAGE AND VALVE

A Division of The Clark • Reliance® Corporation
16633 Foltz Industrial Parkway • Strongsville, OH 44136 USA
Telephone: (440) 572-1500 Fax: (440) 238-8828