

**MAGNE-SONIC  
SERIES 210, 220 & 240  
RF ELECTRONIC  
LEVEL SWITCH**

# TABLE OF CONTENTS

## PART ONE - INTRODUCTION

### SECTION 1 GENERAL INFORMATION

- 1.1 Description
- 1.2 Product Identification

### SECTION 2 SPECIFICATIONS

## PART TWO - INSTALLATION

### SECTION 1 UNPACKING

### SECTION 2 MECHANICAL REQUIREMENTS

- 2.1 Location
- 2.2 Integral Mounting
- 2.3 Remote Mounting

### SECTION 3 ELECTRICAL CONNECTIONS

- 3.1 Level Sensing Element
- 3.2 Push-To-Test Option
- 3.3 Relay Outputs
- 3.4 Line Power

## PART THREE - OPERATION

### SECTION 1 OPERATING CONTROLS

- 1.1 Level Setpoint
- 1.2 Fail Safe Relay Operation
- 1.3 Time Delay
- 1.4 Miscellaneous

### SECTION 2 INSTRUMENT START UP

## SECTION 3

## CALIBRATION

- 3.1 High or Low Alarm/Control
- 3.2 With Driven Shield Type Elements
- 3.3 Differential (Cyclic) Control

## PART FOUR - PRINCIPLE OF OPERATION

## PART FIVE - SERVICE & MAINTENANCE

### SECTION 1

### GENERAL

### SECTION 2

### CUSTOMER ASSISTANCE

## PART SIX - SPARE PARTS

### ILLUSTRATIONS:

- Figure 2-1** Typical Mounting Locations
- Figure 2-2** Integral Mounting
- Figure 2-3** Remote Mounting
- Figure 2-4** Hook-up Details for Remote Mounted Level Element and Remote Push-To-Test Switch Option
- Figure 2-5** Hook-up Details for Relay Outputs and Line Power
- Figure 3-1** Control Panel Layout - No Options
- Figure 3-2** Control Panel Layout - Differential Adjustment Option
- Figure 3-3** Control Panel Layout - Push-To-Test Option
- Figure 4-1** Instrument Operation Schematic

# PART ONE - INTRODUCTION

## SECTION 1- GENERAL INFORMATION

### 1.1 Description

The Series 210 RF level switch is a sensitive electronic point level measuring instrument for level alarm and/or control of conductive and non-conductive liquids, granular materials, foams, pastes, slurries and interface applications.

The instrument contains special shield driver circuitry to ignore the effect of conductive material buildup on the level element surface when used with a driven shield level element.

A relay time delay feature prevents chattering in turbulent materials. The relay can be field configured for a low or high level fail safe operating mode. Optional features include a differential adjustment for high/low cyclic control or a push-to-test option to verify proper system operation.

The Series 210 can be used with any Magne-Sonics bare or insulated level sensing element.

### 1.2 Product ID

The serial number of your instrument is located on the nameplate affixed to the exterior of the enclosure. The matrix on the following page lists all of the instrument options. Use it as a handy reference when re-ordering. Write the serial number in the space provided for convenient identification when technical assistance is required.

**Serial #** \_\_\_\_\_

## SECTION 2 - SPECIFICATIONS

<b>2.1 Operational</b>	Measurement.....	RF impedance/admittance
	Ambient Conditions.....	40 to 71°C (-40 to 160°F), 0 to 100% relative humidity, non-condensing
	Relay Function: Outputs.....	DPDT, two Form C contacts, 5a resistive @ 115/230 VAC and 30 VDC
	Time Delay.....	0 to 20 seconds, field selectable to delay on pull in, drop out or both
	Fail Safe.....	High or low level, field selectable
	Protection.....	RFI, EMI and static charge
	Power.....	115 or 230 VAC, 50/60 Hz; 12 or 24 VDC, 6 watts max.
<b>2.2 Performance</b>	Sensitivity.....	0.2 pF or better
	Temperature Drift .....	0.003 pF per °F
	Adjustment Range .....	0 to 250 pF, zero and operational differential
<b>2.3 Mechanical</b>	Enclosure.....	Cast aluminum w/ urethane finish
	Electrical Classification.....	NEMA 4, 7 BCD and 9 EFG
	Mounting Configurations	
	Integral.....	1/2 inch NPT hole at bottom center of enclosure for direct mounting onto level sensing element
	Remote.....	Requires triaxial cable, sensor mounted explosion proof junction box and remote mount threaded adapter

## PART TWO - INSTALLATION

### SECTION 1 - UNPACKING

After unpacking, carefully unscrew the cover from the base casting and inspect the electronic chassis for shipping damage. If there is any evidence of damage, notify your carrier immediately. Save the small plastic screwdriver and banana plug for later use.

### SECTION 2 - MECHANICAL REQUIREMENTS

#### 2.1 Location

Mounting positions for the level element should be carefully considered. The element may be installed vertically, horizontally or angled, but should not be located where the inflow of material could contact it as this could cause false or sporadic relay actuation. Side mounted level elements with point level controls are typically mounted at a downward angle to allow the measured material to drain or fall from the electrode surface. Vertically mounted level elements must be clear of agitators and other obstructions and far enough from the vessel wall to prevent "bridging" of material between the element and the vessel wall. Electrodes mounted in nozzles should contain a metal "sheath" extending a few inches past the nozzle length. The sheath renders that part of the electrode insensitive, and therefore, ignores the materials which may build up in the nozzle. Figure 2-1 illustrates typical mounting locations.

For applications in which the vessel wall is non-conductive, a grounded reference plate or grounded reference electrode is required. However, if the measured material is conductive and effectively grounded in some other way, a grounded reference plate or grounded electrode is not necessary.

The Series 210 may be installed directly onto the level sensing element (integral mounting) or in a remote location up to 25 feet from the level element. Remote mounting is necessary when the temperature near the level element exceeds the Series 210's rated specification (-40 to 160°F) or if severe vibration exists.

Figure 2-1 Typical Mounting Locations

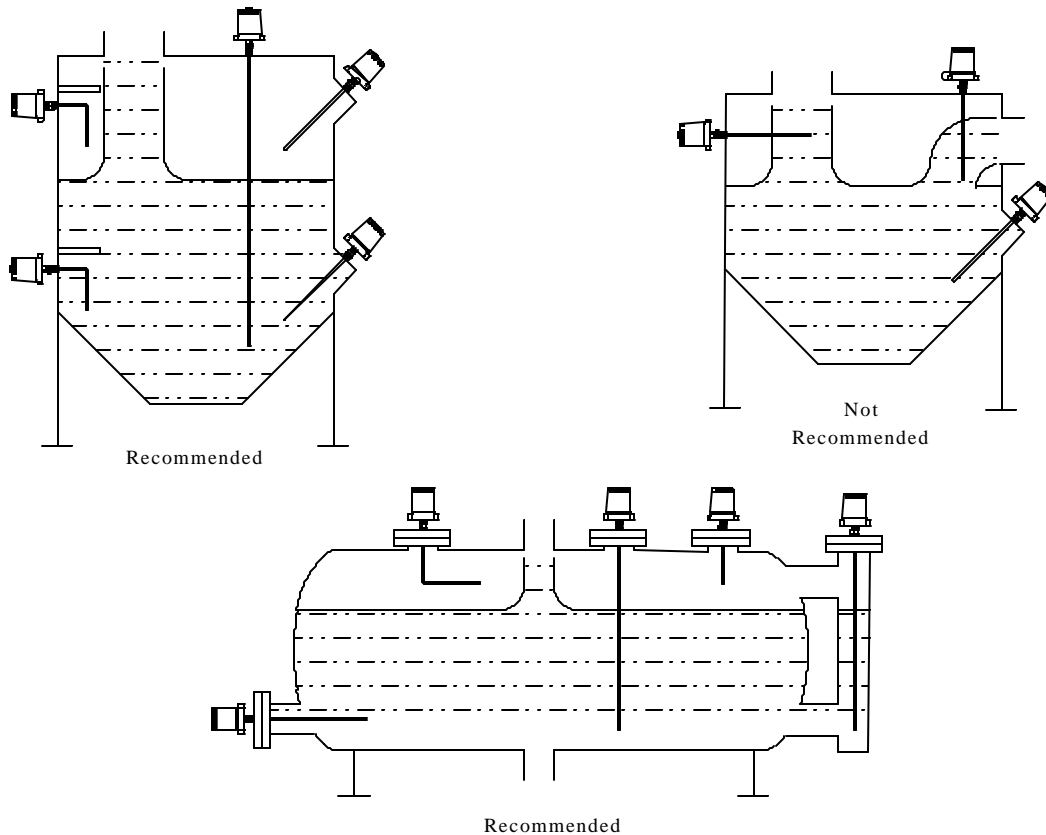

**Note!:** *Triaxial interconnect cable must be used for remote mounting.*

## 2.2 Integral Mounting

Before installing the level sensing element and Series 210, it is recommended to perform the simple bench test described in Part Three, Section 2 to familiarize yourself with the instrument.

The Series 210 has a 1/2" NPT hole on the bottom center of the enclosure for direct mounting onto the installed level sensing element. Follow these steps to install the level element and Series 210.

1. Install level element into vessel opening without the Series 210 mounted onto it. Use a wrench only on the larger lower hex nut portion of the two piece fitting to tighten level element into vessel.

**Caution!:** Do not tighten or loosen the smaller upper hex nut portion of the two piece fitting. This is a compression seal that could be destroyed if the upper portion is turned.

If level element is welded into a mounting flange, simply bolt flange to the mating flange on the vessel.

2. Install banana plug onto back end of level element extension by screwing it into the threaded hole.

Figure 2-2 Integral Mounting

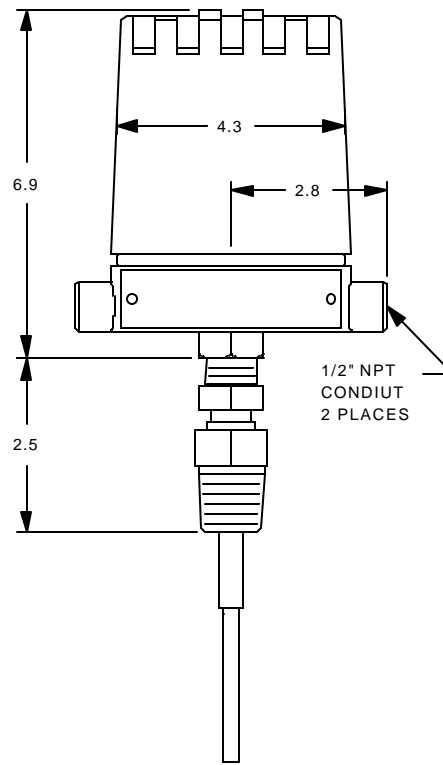

**Caution!:** Do not tighten plug with excessive force as it can be easily twisted off.

3. Carefully screw the Series 210 enclosure casting onto threaded upper portion of fitting on back end of level element. The banana plug makes the necessary electrical connection to the electronic chassis. Screw until tight, but without excessive force to avoid stripping the aluminum threads.

**Note!: It may be necessary to rotate casting to orient wiring entrances to a desired position. Use a wrench to hold the upper smaller hex nut stationary while turning the casting.**

### 2.3 Remote Mounting

Before installing the level sensing element and the Series 210, it is recommended to perform the simple bench test described in Part Three, Section 2 to familiarize yourself with the instrument.

A junction box for mounting onto the level element, a remote mount threaded adapter and triaxial interconnect cable are required to remotely mount the Series 210.

1. Install level element into vessel opening or flange mounting as described in Section 2.2, step 1.
2. Carefully screw junction box onto threaded upper portion of fitting on back end of level element. Use the same precaution regarding the compression seal as described in Section 2.2-step 1 when tightening and orienting junction box onto top of level element.

Figure 2-3 Remote Mounting

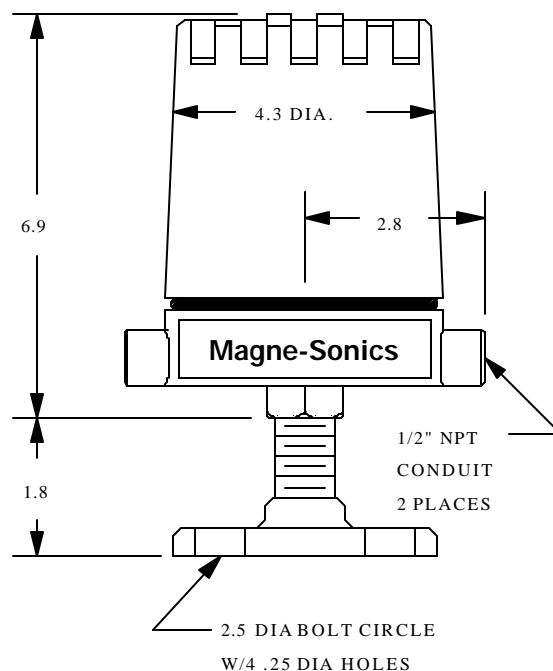

3. Install remote mount threaded adapter into 1/2 inch NPT opening in bottom of the Series 210 enclosure casting.

***Note!:*** ***This must be a solid fitting to preserve the explosion proof rating of the instrument. (Should fitting become lost, do not use a pipe nipple in explosion proof installations. Also, use only approved explosion proof wiring seal fittings in the conduit entrances. These are not provided.***

4. Surface mount the Series 210 with remote mount threaded adapter within 25 feet of the installed level element.

## SECTION 3 - ELECTRICAL CONNECTIONS

### 3.1 Level Sensing Element

#### **Integral Mounting**

The level element is connected to the Series 210 via the banana plug on the back end of the element. Verify that the plug is installed properly and is not damaged.

#### **Remote Mounting**

Use only triaxial interconnect cable to connect junction box and the Series 210. Any other type of cable causes incorrect instrument operation. Connect triaxial cable, matching wires to terminals as follows.

<u>Triaxial Cable</u>	<u>Terminal Designation</u>
Center Wire	PROBE
Blue Wire (inner braid)	SHIELD
Green Wire (outer braid)	Ground Symbol

Figure 2-4 Hook-up Details for Remote Mounted Level Elements and Push-To-Test Switch Option

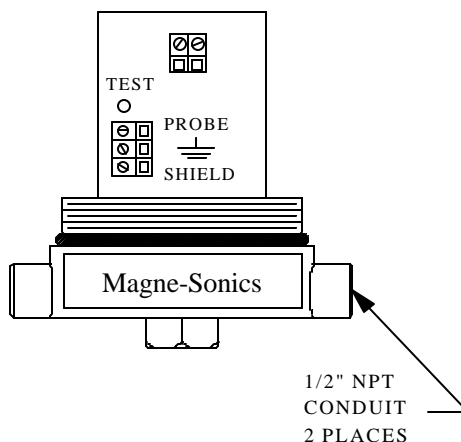

### 3.2 Push-To-Test Option

When Series 210 has the optional push-to test feature, the operator can test for high level (overflow) alarm operation without actually filling the vessel. The test can be performed locally using the instruments **TEST** button or remotely with a "test" switch. A spring return, momentary contact type switch or push-button is recommended. Connect remote "test" switch to TEST terminals (Figure 2-4). The local **TEST** button remains operational.

### 3.3 Relay Outputs

Two sets of relay outputs are provided (Figure 2-5). These terminals are not powered.

*Note!:* Terminal designations are shown with relay in the de-energized state. This is important and will have an effect on control wiring depending on the fail safe mode of operation selected (Part Three, Section 1.2).

Always check control wiring to insure that line power will not be shorted by the switching action of the relay contacts.

**Caution!:** Do not exceed the relay's contact rating of 5A, 115/230 VAC. Use an adequate wire size rated for the load.

Figure 2-5 Hook-up Details for Relay Outputs and Line Power

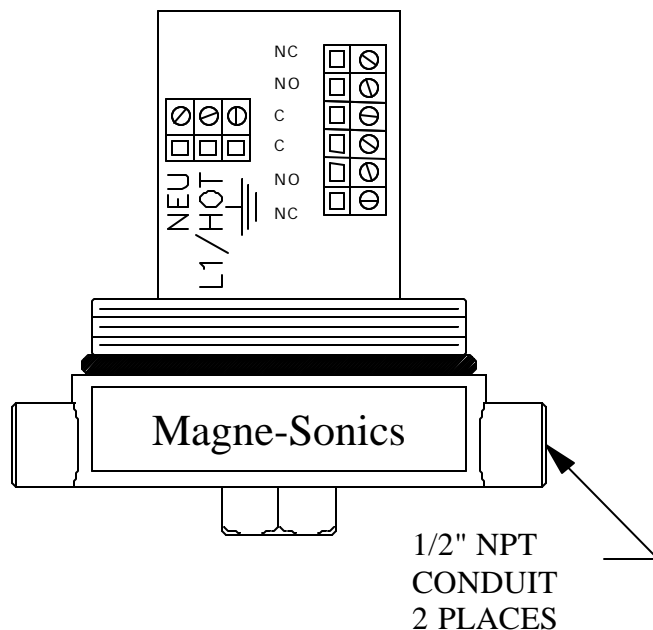

### 3.4 Line Power

Power requirements may be 115 VAC, 230 VAC, 12 VDC or 24 VDC depending on the model selected. Check to make sure which voltage is correct for the unit being installed. Connect appropriate power to NEU, L1/HOT and GND terminals (Figure 2-5) which are fuse protected. Wire size of #12 AWG is recommended for primary power and control circuit wiring. Use wiring practices which conform to local codes (National Electrical Code Handbook in the U.S.A.). Use only the standard three wire connection for AC wiring. The ground terminal grounds the instrument which is mandatory for safe operation.

**WARNING!: APPROVED SEAL FITTINGS MUST BE USED IN THE CONDUIT OPENINGS TO PRESERVE THE EXPLOSION PROOF RATING. UNUSED CONDUIT OPENINGS MUST BE SEALED USING A SOLID PIPE PLUG.**

# PART THREE - OPERATION

## SECTION 1 - OPERATING CONTROLS

All operating controls and calibration adjustments are clearly marked and accessed by unscrewing the top cover from the enclosure casting. Use the small plastic screwdriver provided to make control adjustments. Do not force any adjustment past its stops to avoid breakage.

### 1.1 Level Setpoint

1. **ZERO COARSE** and optional **DIFF.** or **TEST COARSE** switches.

Selects level setpoint range. Positions 0 through 9 progressively add 25 pF to the **FINE** control (item 2) adjustment. This switch is used in combination with **FINE** control to set level control points.

2. **ZERO FINE** and optional **DIFF.** or **TEST FINE** controls
3. **HIGH LEVEL** indicator (red LED)

### 1.2 Fail Safe Operation

4. **FAIL SAFE** switch

HIGH - Selects relay to be energized when the level is below a horizontally or angle mounted level element or is below the setpoint on a vertically mounted level element. The relay de-energizes when the level rises above the level element or setpoint.

***NOTE!:*** *In the event of power failure or most component failures, the relay would naturally be in the de-energized state. The system, therefore, fails safely. For additional safety, The control contacts of the relay should be wired to a separate power source.*

LOW - Selects relay to be energized when the level rises above a horizontally or angle mounted level element or rises above the setpoint on a vertically mounted sensor.

### 1.3 Time Delay

#### 5. **HI** and **LOW DELAY** switches

These switches, in conjunction with the **DELAY ADJ.** control (item 6), may be used to provide relay time delay to prevent contact chattering or sporadic operation in turbulent materials.

NONE - Selects relay to operate without time delay

ADJ. - Selects relay to operate with a time delay. With **HI DELAY** switch in this position, relay action will occur a preset time after level rises above the level element or setpoint. With **LO DELAY** switch in this position, relay action will occur a preset time after level falls below the level element or setpoint. With both switches set to **ADJ.** position, delay will occur both on rising and falling level. The delay time (0-20 seconds), preset with the **DELAY ADJ.** control, is the same for both delay modes.

#### 6. **DELAY ADJ.** control

Adjusts relay delay time from 0 to 20 seconds when **HI DELAY** and/or **LO DELAY** switch is in **ADJ.** position.

### 1.4 Miscellaneous

#### 7. **FUSE** (1/4 amp)

Twist cap type fuse is properly rated for the same instrument. It should be replaced only with a fuse of the same rating.

***Note!:*** *The fuse does not protect the relay output control wiring. These circuits and the primary power should be connected through adequately rated circuit breakers.*

**Figure 3-1 Control Panel Layout – No Options**

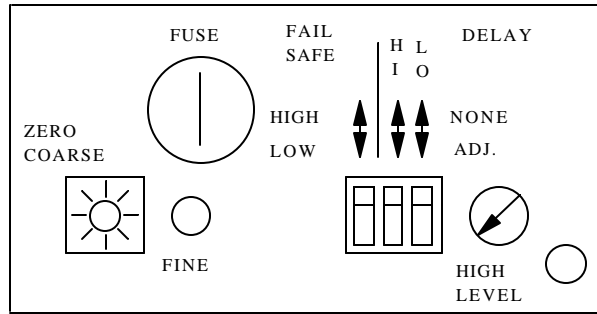

**Figure 3-2 Control Panel Layout – Differential Adjustment Option**

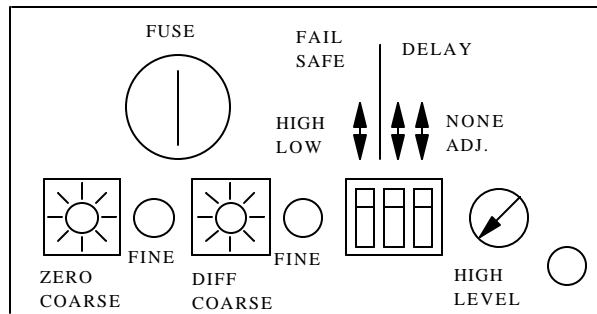

**Figure 3-3 Control Panel Layout – Push-To-Test Option**

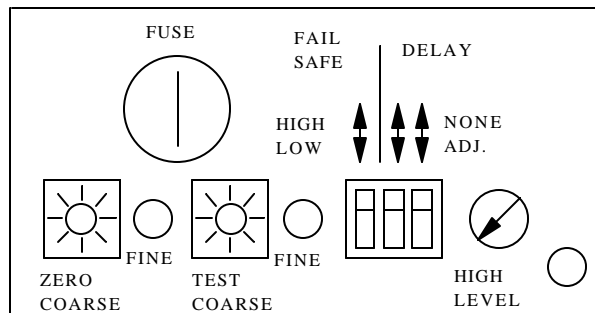

## SECTION 2 - INSTRUMENT START UP (BENCH TEST)

It is recommended to become familiar with the controller before actual installation. Performing these simple steps will accomplish this purpose and, at the same time, test the instrument.

The procedure must be done with the level element connected to the Series 210. Make sure the banana plug is installed onto the back end of the level element extension to make electrical contact with the unit. If remote mounting is to be used, the triaxial cable should be connected to the unit.

**WARNING!:** IN HAZARDOUS AREA LOCATIONS, IT IS NECESSARY TO OBTAIN PLANT SAFETY DEPARTMENT APPROVAL BEFORE OPENING THE ENCLOSURE CASING WHILE CIRCUITS ARE POWERED.

1. Clamp the larger, lower portion of the level element fitting into a vise if possible. Otherwise, lay the element on a wooden bench and use some blocks to hold it in a steady position.
2. Place the following controls and switches to these settings:

<u>Control</u>	<u>Setting</u>
<b>ZERO COARSE</b> .....	<b>0</b>
Optional <b>DIFF.</b> or	
<b>TEST COARSE</b> .....	<b>0</b>
<b>FINE Control(s)</b> .....	Fully Counterclockwise
<b>FAIL SAFE</b> .....	<b>HIGH</b>
<b>HI DELAY</b> .....	<b>NONE</b>
<b>LO DELAY</b> .....	<b>NONE</b>
<b>DELAY ADJ.</b> .....	Fully Counterclockwise

3. Connect power to appropriately marked terminals. It is not necessary to connect a load to the relay terminals for this test. The **HIGH LEVEL** indicator should be lit. If not check the fuse.

4. Turn **ZERO COARSE** step switch clockwise (right) until relay transfers and **HIGH LEVEL** indicator goes off. Turn switch back one position step. The LED should come on again.
5. Turn **ZERO FINE** control slowly clockwise (right) until relay transfers and **HIGH LEVEL** indicator goes off. Turn control clockwise 1/2 turn beyond this point and leave it at this setting. This is the level setpoint.
6. Bring your hand to the level element surface. This simulates level approaching the probe.

*Note!:* **Relay may transfer before actually touching the probe surface. Move your hand back and forth and observe the relay action.**

7. Add time delay to the relay action.
  - A. Set **HI DELAY** switch to **ADJ.** position and turn blue **DELAY ADJ.** control a few degrees clockwise. Repeat step 6. Notice that relay action does not occur until some time elapses after removing your hand from the probe.
  - B. Return **HI DELAY** switch to **NONE** and set **LO DELAY** switch to **ADJ.** Repeat step 6. Notice that relay action does not occur until some time elapses after removing your hand from the probe.
  - C. Set both **HI** and **LO DELAY** switches to **ADJ.** position and repeat step 6. Notice that relay action does not occur until some time elapses after removing your hand from the probe.
  - D. Increase delay time by turning blue **DELAY ADJ.** control clockwise. The maximum delay is approximately 20 seconds.
  - E. Reset **HI** and **LO DELAY** switches to **NONE** and return **DELAY ADJ.** control to a fully counterclockwise setting.

8. If instrument is equipped with push-to-test option, set **TEST COARSE** step switch to position 1 and depress **TEST** push-button (Figure 2-4) momentarily. Notice that relay action occurs. This simulates level reaching the probe.
9. Set **FAIL SAFE** switch to **LO** position. Notice that relay transfers, but **HIGH LEVEL** indication remains the same: on at high level and off at low level. Return **FAIL SAFE** switch to **HIGH** position.
10. If the instrument is equipped with differential adjustment option, turn **DIFF. FINE** control clockwise about 5 turns. Notice that in bringing your hand to the probe as in step 6, it is necessary to come much closer to the probe surface. Increasing the setting clockwise would require actually grasping the probe with your hand to make the relay transfer. (Increasing setting actually raises the high level setpoint).

## SECTION 3 - CALIBRATION

### 3.1 High or Low Alarm/Control

With material level below installed level element:

1. Disconnect relay outputs to prevent actuation of final control elements.
2. Place the following controls and switches to these settings:

<u>Control</u>	<u>Setting</u>
<b>ZERO COARSE</b> .....	<b>0</b>
<b>ZERO FINE</b> .....	Fully Counterclockwise
<b>FAIL SAFE</b> .....	<b>HIGH</b> or <b>LOW</b>
<b>HI DELAY</b> .....	<b>NONE</b>
<b>LO DELAY</b> .....	<b>NONE</b>
<b>DELAY ADJ.</b> .....	Fully Counterclockwise

3. Apply power to the instrument. The **HIGH LEVEL** indicator should light. If the probe is vertical and the level setpoint is desired anywhere along its length (at least two inches from the tip), manually bring the level to the desired control point and perform steps 4 and 5.
4. Turn **ZERO COARSE** switch clockwise until relay transfers and **HI LEVEL** indicator goes off. Turn switch back one position step. The LED should come on again.
5. Turn **ZERO FINE** control slowly clockwise (right) until LED goes off. This is the level setpoint. Turn control counterclockwise 1/2 to 1 turn beyond this point and leave it at this setting.
6. Add time delay to relay action if desired. Set **HI DELAY**, **LO DELAY** or both switches to **ADJ.** position and turn blue **DELAY ADJ.** control clockwise to increase the delay.
7. If instrument is equipped with push-to-test option, simply depress **TEST** push-button. The **HI LEVEL** indicator should light. If not, continue holding **TEST** push-button in and turn **TEST FINE** control clockwise until LED lights. If LED not light after turning **TEST FINE** control through its

full adjustment range (about 40 turns), return **TEST FINE** control to fully counterclockwise setting and increase **TEST COARSE** switch one position. Then turn **TEST FINE** control clockwise until LED lights. It may be necessary to repeat this sequence if the desired control point is very distant from the probe tip and the dielectric constant of the measured material is high or the material is conductive.

### **3.2 With Driven Shield Type**

#### **Level Elements**

The driven shield type level element is not insulated at the lower measuring section and it contains a electronically driven section. Since the driven section is automatically maintained at the same potential as the measuring section, it tends to block current flow to ground through any conductive coating which may build up on the probe surface. Without this special feature, a conductive coating could provide a short circuit path to ground and force the Series 210 to indicate high level at all times. Note these important points:

- \* Driven shield type level elements are not used in differential control applications.
  - \* If the probe is installed in a pipe extension or nozzle, the insulated portion of the shield element must extend at least four inches past the end of the extension or nozzle.
1. It is recommended to manually cycle the level several times to allow any buildup on the probe to occur before calibration.
  2. With material level below installed level element, refer to Section 3.1 and perform steps 1 through 7.

### **3.3 Differential (Cyclic) Control**

For differential (cyclic) control, the level sensing element must be an insulated type and it must be installed vertically.

1. Disconnect relay outputs to prevent actuation of final control elements.

- Place the following controls and switches to these settings:

<u>Control</u>	<u>Setting</u>
<b>ZERO and DIFF.</b>	
<b>COARSE</b> .....	<b>0</b>
<b>ZERO and DIFF.</b>	
<b>FINE</b> .....	Fully Counterclockwise
<b>FAIL SAFE</b> .....	<b>HIGH</b> or <b>LOW</b>
<b>HI DELAY</b> .....	<b>NONE</b>
<b>LO DELAY</b> .....	<b>NONE</b>
<b>DELAY ADJ.</b> .....	Fully Counterclockwise

- Manually bring material level to desired low level control point (at least 2 inches from probe tip).
- Apply power to the instrument. The **HIGH LEVEL** indicator should light.
- Turn **ZERO COARSE** switch clockwise until transfers and **HI LEVEL** indicator goes off. Turn switch back one position step. The LED should come on again.
- Turn **ZERO FINE** control slowly clockwise (right) until LED goes off. This is the low level control point. Leave it at this setting.
- Turn **DIFF. COARSE** switch to position 9 and **DIFF. FINE** control fully counterclockwise (about 40 turns). This sets the differential at maximum.
- Manually bring material level to desired high level control point (no higher than 2 inches from top of probe). The LED should remain off.

*Note!: If LED lights while raising level, the maximum differential has been exceeded. This will be about four feet of a high dielectric constant or conductive material using a standard duty insulated type probe. It may be necessary to select a lower high level control point and start calibration again.*

9. Turn **DIFF. COARSE** switch counterclockwise (left) until LED comes ON.
10. Turn **DIFF. FINE** control fully clockwise and press RESET, turn **DIFF. FINE** counterclockwise until LED comes on. (This is the high level set point.)
11. Reconnect control device(s) to relay outputs and replace cover on the Series 210 enclosure casting.

## PART FOUR - PRINCIPLE OF OPERATION

See Figure 4-1 for a simplified schematic diagram pertaining to these descriptions:

1. The power supply section (not shown) converts line power to appropriate voltages for circuit operation.
2. In the DETECTOR section, the output of a square wave oscillator is capacitively coupled to a quad diode bridge. The diodes steer current, in alternating states of the oscillator output, to a reference "zero" capacitor and to the impedance at the probe. A DC offset voltage is developed at the coupling capacitors so that the AC currents through the reference and probe legs of the bridge are equal. This voltage is amplified and presented to Schmitt trigger circuit. The output is low on high level, high on low level.
3. The square wave oscillator output in the detector section is by the shield driver and connected to the shield of the optional driven shield probe and/or to the inner shield of a triaxial cable. In this way, a low impedance signal equal to the probe signal is interposed between the probe lead and ground. This prevents current flow either through a coating on the driven shield probe or through the capacitance between the center conductor and outer shield of the cable.
4. The output from the detector section is presented to the TIME DELAY section where it charges a capacitor through a variable resistor. This resistor determines how quickly the capacitor charges or discharges. the voltage on the

capacitor is fed to a Schmitt trigger to produce an output signal which is high on high level. Selector switches and diodes allow instant charge or discharge of the capacitor to allow for instantaneous action on high or low level.

5. The output of the time delay section is fed to the FAIL SAFE selection section. The amplifier in this section acts as a buffer or an inverter depending upon the state of the fail safe switch. When the switch is closed, the unit is in high fail safe. The amplifier acts as an inverter whose output is low on high level. When the switch is open, the unit is in low fail safe. The amplifier now acts as a buffer so that the output is high on high level.
6. The OUTPUT section consists of a DPDT control relay and a transistor drive circuit. A high level to the transistor from the fail safe section energizes the relay.
7. The optional DIFFERENTIAL section receives its input from the time delay section. The input, which is high on high level, is applied to transistor drive circuit which controls a relay. This relay is used to apply an additional amount of capacitance in parallel to the "zero" capacitance when the level is low. When the level is high enough to exceed the capacitance of the "zero" and "differential" capacitors, the unit switches and relay is energized. This removes the "differential" capacitor from the detector circuit so that the level must fall enough to produce a capacitance less than the "zero" capacitance before low level is sensed by the unit.
8. The optional PUSH-TO-TEST circuit (not shown) uses a relay to apply a variable capacitor in parallel with the probe when the **TEST** push-button is pressed or when a remote switch is actuated. In high level alarm applications, this can be used to simulate increased level on the probe and will test the integrity of the unit and the calibration.

Figure 4-1 Instrument Operations Schematic Diagram

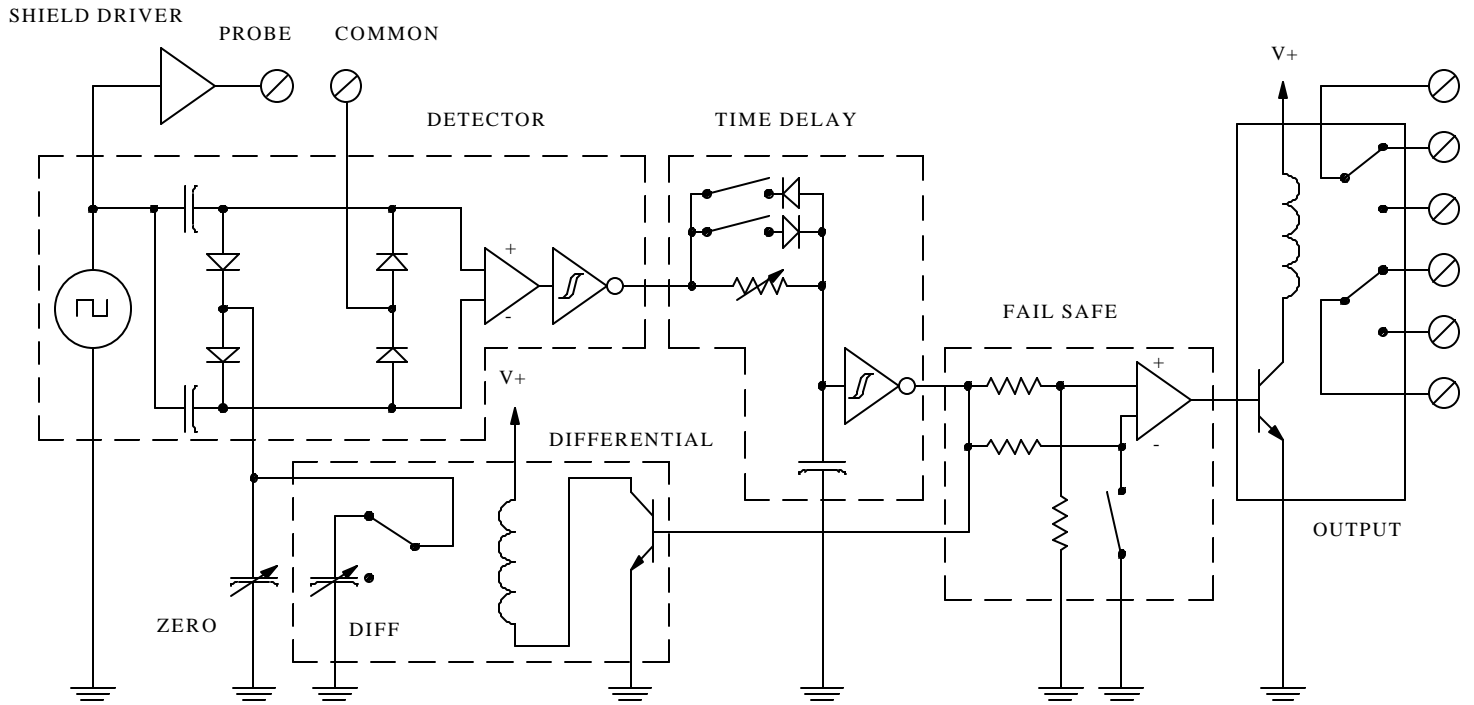

## **PART FIVE - SERVICE & MAINTENANCE**

### **SECTION 1 - GENERAL**

The electronic chassis assembly is held into the enclosure with two screws in the bottom of the chassis. These are accessible from the side of the chassis.

Replacement of circuit board components should be performed by a qualified technician. Otherwise, return the entire chassis assembly to the factory after obtaining a return authorization. If possible, include a brief description of the trouble symptoms.

In some applications it may be necessary to clean the probe periodically.

### **SECTION 2 - CUSTOMER ASSISTANCE**

Should service, parts or assistance in troubleshooting or repair be required, please contact your Magne-Sonic representative or the Magne-Sonic Customer Service Department:

**Magne-Sonic Corporation**  
**9441 West Sam Houston PKWY , Ste 100**  
**Houston, Texas 77099**

**tel: (713) 785-4400**  
**fax: (713) 785-1826**

When ordering spare or replacement electronic chassis assemblies, be sure to use the **COMPLETE** assembly part number.

A description of the malfunction as well as the proper return address should accompany all electronic chassis assemblies returned for repair, freight prepaid. All chassis assemblies out of warranty should be accompanied by a purchase order to cover costs of repair.

*Note!: If the instrument or chassis assembly is damaged during return shipment as a result of inadequate packaging, the customer assumes responsibility for repair costs. It is recommended to use the original shipping carton or an equivalent. Also, Magne-Sonics will not accept instruments returned for repair or replacement unless they are thoroughly cleaned and all process material is removed.*

**PART SIX - SPARE PARTS & ACCESSORIES**

	<u>Description</u>	<u>Part Number</u>
<b>Parts for Remote Mounting</b>	Threaded Adapter .....	1000-3071
	Explosion proof J-Box (with jack & terminal strip).....	1000-3072
	Triaxial Interconnect Cable* (for temperatures to 160°f).....	1000-3073
	Triaxial Interconnect Cable* (for temperatures to 450°f).....	1000-3074
	* Cable has stripped and tinned wires at each end. Specify length up to 25 feet.	
<b>Miscellaneous Parts</b>	Fuse, 1/4 Amp Slo-Blow.....	99X1F1036
	Relay, 5A Contacts, 12 VDC Coil.....	99X2T1026
	Trimmer Capacitor (30 pF).....	99X8C0001