

**MAGNE-SONIC  
SERIES 110 & 120  
CONDUCTIVITY SWITCH**

# TABLE OF CONTENTS

## PART ONE - INTRODUCTION

<b>SECTION 1</b>	<b>GENERAL INFORMATION</b> 1.1 Description 1.2 Product Identification
<b>SECTION 2</b>	<b>SPECIFICATIONS</b>

## PART TWO - INSTALLATION

<b>SECTION 1</b>	<b>UNPACKING</b>
<b>SECTION 2</b>	<b>MECHANICAL REQUIREMENTS</b> 2.1 Location 2.2 Integral Mounting 2.3 Remote Mounting
<b>SECTION 3</b>	<b>ELECTRICAL CONNECTIONS</b> 3.1 Level Sensing Element 3.2 Push-To-Test Option 3.3 Relay Outputs 3.4 Line Power

## PART THREE - OPERATION

<b>SECTION 1</b>	<b>OPERATING CONTROLS</b> 1.1 Input Select 1.2 Sensitivity Select 1.3 High Level Alarm 1.4 Fail Safe Relay Operation 1.5 Relay Time Delay 1.6 Miscellaneous
<b>SECTION 2</b>	<b>INITIAL SETUP</b> 2.1 High or Low Alarm/Control 2.2 Push-To-Test Option

## **PART FOUR - PRINCIPLE OF OPERATION**

## **PART FIVE - SERVICE & MAINTENANCE**

**SECTION 1                      GENERAL**

**SECTION 2                      CUSTOMER ASSISTANCE**

## **PART SIX - SPARE PARTS**

**ILLUSTRATIONS**

**Figure 2-1** Typical Mounting Locations

**Figure 2-2** Integral Mounting

**Figure 2-3** Remote Mounting

**Figure 2-4** Hook-up Details for Remote Mounted Level Element and Push-To-Test Switch Option

**Figure 2-5** Hook-up Details for Relay Outputs

**Figure 2-6** Hook-up Details for Relay Outputs and Line Power

**Figure 3-1** Control Panel Layout

**Figure 4-1** Instrument Operations Schematic Diagram

# PART ONE - INTRODUCTION

## SECTION 1 - GENERAL INFORMATION

### 1.1 Description

The series 110 conductivity switch is a sensitive electronic relay that is used for point level alarm and/or control of conductive liquids, foams, pastes and damp or conductive granular materials. (Applications which tend to form a coating on the sensing element which dry and become an insulator should be avoided. The Series 210 RF electronic level switch is recommended for these applications).

The relay will trip when the resistance between the level sensing element and a ground rod or a metal vessel wall falls below 1 megohm (high sensitivity mode) or 100,000 ohms (low sensitivity mode). A relay time delay feature prevents chattering in turbulent materials. The relay can be field configured for a low or a high level fail safe operating mode. Optional features include differential capability for use with two probe inputs for high/low cyclic control or a push-to-test provision to test for high level (overflow) alarm operation. The Series 110 can be used with any Magne-Sonics bare level sensing element.

The serial number of your instrument is located on the electronic chassis next to the power input terminals. The matrix on the following page lists all of the instrument options. Use it as a handy reference when re-ordering. Write the serial number in the space provided for convenient identification when technical assistance is required.

**Serial #** \_\_\_\_\_



## SECTION 2 - SPECIFICATIONS

<b>2.1 Operational</b>	Measurement..... AC Resistance
	Ambient Conditions..... -40 to 71°C (-40 to 160°F), 0 to 100% relative humidity, non-condensing
	Relay Function:
	Outputs..... DPDT, two Form C contacts, 5A resistive @ 115/230 VAC and 30 VDC
	Time Delay..... 0 to 20 seconds, field selectable to delay on pull-in, drop-out or both ways
	Fail Safe..... High or low level, field selectable
	Power Requirements..... 115 or 230 VAC, 50/60 Hz
<b>2.2 Performance</b>	Sensitivity ..... 1.0 megohm (high sensitivity) 100,00 ohms (low sensitivity)
<b>2.3 Mechanical</b>	Enclosure..... Cast aluminum w/urethane finish
	Electrical Classification....NEMA 4, 7 BCD and 9 EFG (weatherproof, hosedown, dust and vapor explosion proof)
	Mounting Configurations:
	Integral.....1/2 inch NPT hole at bottom center of enclosure for direct mounting onto level sensing element
	Remote..... Requires two-conductor interconnectable, sensor mounted explosion proof junction box and remote mount threaded adapter

## PART TWO - INSTALLATION

### SECTION 1 - UNPACKING

After unpacking, carefully unscrew the cover from the base casting and inspect the electronic chassis for shipping damage. If there is any evidence of damage, notify your carrier immediately. Save the small plastic screwdriver and banana plug for later use.

### SECTION 2 - MECHANICAL REQUIREMENTS

#### 2.1 Location

Mounting positions for the level detecting element should be carefully considered. Avoid mounting electrodes where the inflow of material could directly contact them (causes false or sporadic relay actuation).

Conductivity type level sensing electrodes are "tip sensitive". When conductive material reaches the electrode tip, a circuit path to a ground electrode or metal vessel wall is completed, causing the relay to trip. The relay trip point cannot be adjusted over the length of the electrode. Consequently, the length of a vertically mounted electrode determines the control point.

Typically, conductivity type electrodes are mounted vertically, but can be side mounted preferably angled downward to allow the measured material to drain or fall from the electrode surface. For materials which tend to build up on the electrode surface, vertical mounting is recommended. Figure 2-1 illustrates typical mounting locations.

For applications in which the vessel wall is non-conductive, a grounded reference plate or grounded reference electrode is required. However, if the measured material is effectively grounded in some other way, a grounded reference plate or ground electrode is not required.

The Series 110 may be installed directly onto the level sensing element (integral mounting) or in a remote location up to 1000 feet from the level element. Remote mounting is necessary when the temperature at the Series 110 exceeds its rated specification (-40 to 160°F) or if severe vibration exists.

Remote mounting is also required when the Series 110 is equipped with the differential option which uses two level sensing elements.

*Figure 2-1 Typical Mounting Locations*

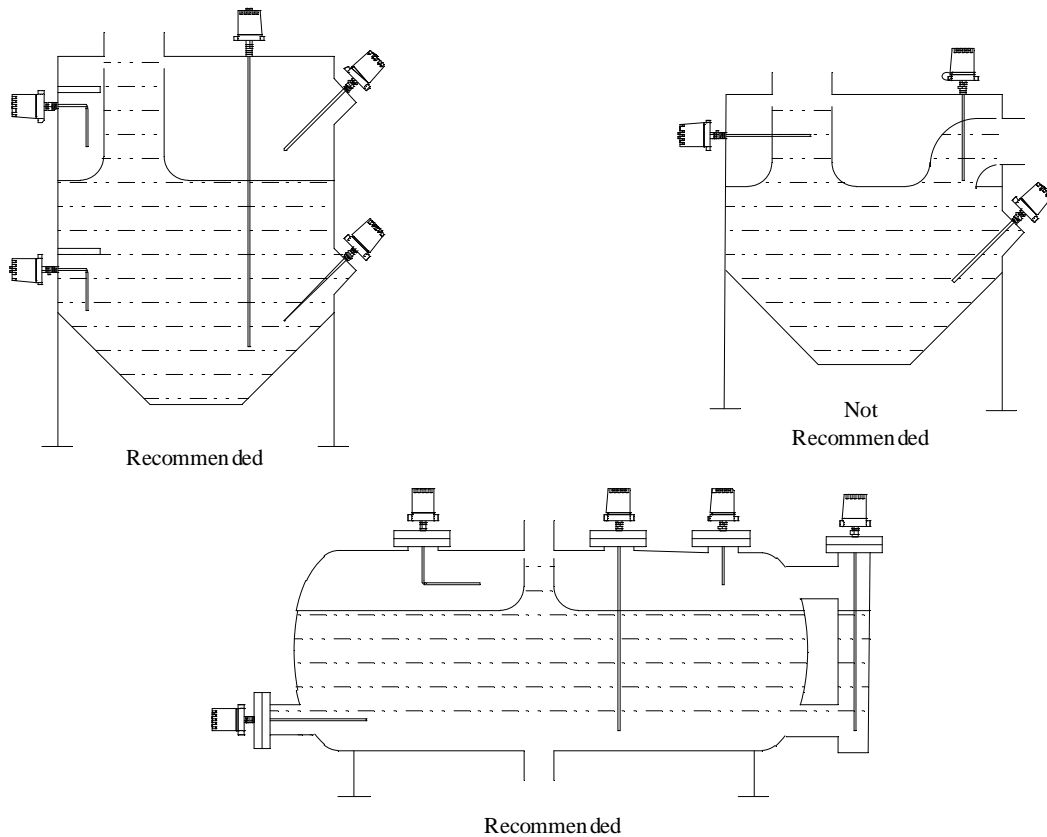

## 2.2 Integral Mounting

The Series 110 has a 1/2 inch NPT hole on the bottom center of the enclosure for direct mounting onto the installed level sensing element. Follow these steps to install the level element and the Series 110.

1. Install the level element into vessel opening without the Series 110 mounted onto it. Use a wrench only on the larger lower hex nut portion of the two-piece fitting to tighten level element into vessel.

**Caution!:** Do not tighten or loosen the smaller upper hex nut portion of the two piece fitting. This is a compression seal that could be destroyed if the upper portion is turned.

If level element is welded into a mounting flange, simply bolt flange to the mating flange on the vessel.

2. Install banana plug onto back end of level element extension by screwing it into the threaded hole.

**Caution!:** Do not tighten plug with excessive force as it can be easily twisted off.

*Figure 2-2 Integral Mounting*

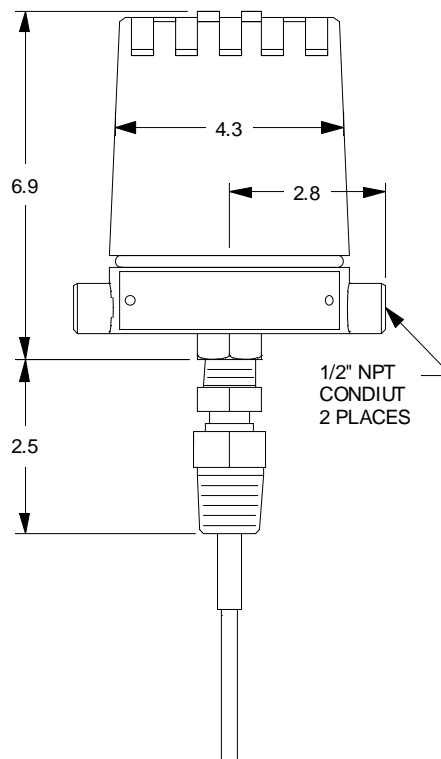

3. Carefully screw the Series 110 enclosure casting onto threaded upper portion of fitting on back end of level element. The banana plug makes the necessary electrical connection to the electronic chassis. Screw until tight, but without excessive force to avoid stripping the aluminum threads.

***Note!:*** *It may be necessary to rotate casting to orient wiring entrances to a desired position. Use a wrench to hold the upper smaller hex nut stationary while turning the casting.*

### **2.3 Remote Mounting**

A junction box for mounting onto the level element, a remote mount threaded adapter and two-conductor interconnect cable are required to remotely mount the Series 110.

1. Install the level element into vessel opening or flange mounting as described in Section 2.2, step 1.
2. Carefully screw junction box onto threaded upper portion of fitting on back end of level element. Use same precaution regarding the compression seal as described in Section 2.2-step 1 when tightening and orienting junction box onto top of level element.
3. Install remote mount threaded adapter into 1/2 inch NPT opening in bottom of Series 110 enclosure casting.

***Note!:*** *This must be a solid fitting to preserve the explosion proof rating of the instrument. (Should fitting become lost, do not use a pipe nipple in explosion proof installations. Also, use only approved explosion proof wiring seal fittings in the conduit entrances. These are not provided).*

4. Surface mount the Series 110 with remote mount threaded adapter within 1000 feet of the installed level element.

Figure 2-3 Remote Mounting

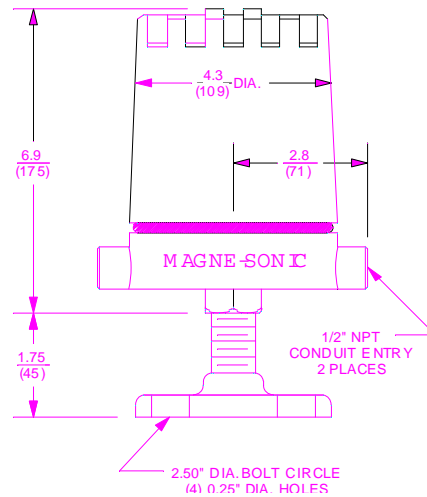

## SECTION 3 - ELECTRICAL CONNECTIONS

### 3.1 Level Sensing Element

- Integral Mounting**      The level element is connected to the Series 110 via the banana plug on the back end of the element. Verify that the plug is installed properly and is not damaged.
- Remote Mounting**      Use a two conductor interconnect cable to connect level element junction box to the Series 110.
1. At the junction box, connect red wire to PROBE terminal and black wire to ground symbol terminal. Disregard the shield connection.
  2. At the Series 110, connect red wire to PROBE terminal and black wire to common terminal.

**NOTE!:** A ground wire attached to a metal vessel may be connected to the COMMON terminal. If vessel is non-conductive, (plastic, fiberglass, etc.), a separate ground electrode must be connected to COMMON terminal. If level sensing element is vertically mounted, the ground electrode must be at least equal in length or longer. If level sensing element is mounted horizontally or at a downward angle, the ground element must be positioned so that it completes a circuit path with the level sensing element when the level reaches the sensing electrode

Figure 2-4 Hook-up Details for Remote Mounted Level Element and Push-To-Test Switch Option

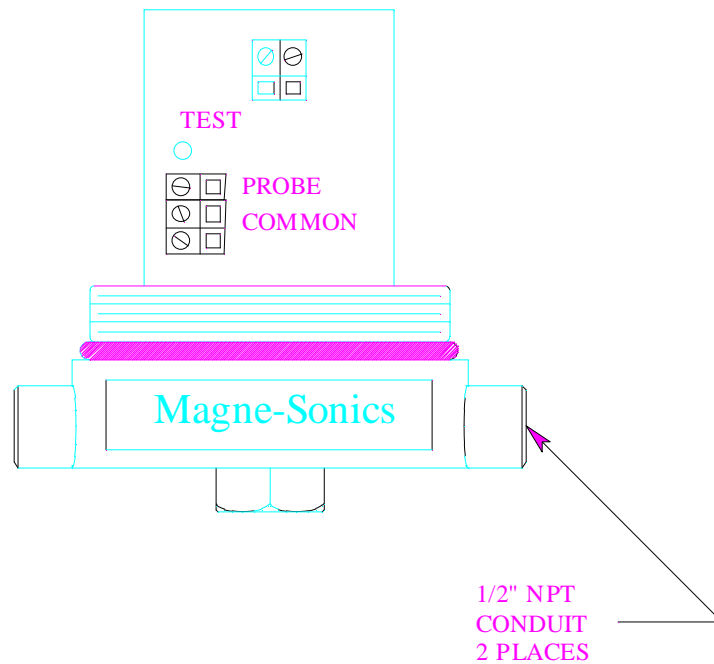

### 3.2 Push-To-Test Option

When the Series 110 has the optional push-to-test feature, the operator can test for high level (overflow) alarm operation without actually filling the vessel. The test can be performed locally using the instrument's **TEST** button or remotely with a "test" switch. A spring return, momentary type contact type switch or push-button is recommended. Connect remote "test" switch to TEST terminals on TB2 (Figure 2-4). The local **TEST** button remains operational.

### 3.3 Relay Outputs

Two sets of relay outputs are provided (Figure 2-6). These terminals are not powered.

*Note!:* Terminal designations are shown with relay in the de-energized state. This is important and will have an effect on control wiring depending on the fail safe mode of operation selected (Part Three, Section 1.4).

Always check control wiring to insure that line power will not be shorted by the switching action of the relay contacts.

**Caution!:** Do not exceed the relay's contact rating of 5A 115/230 VAC. Use an adequate wire size rated for the load.

Figure 2-6 Hook-up Details for Relay Outputs and Line Power

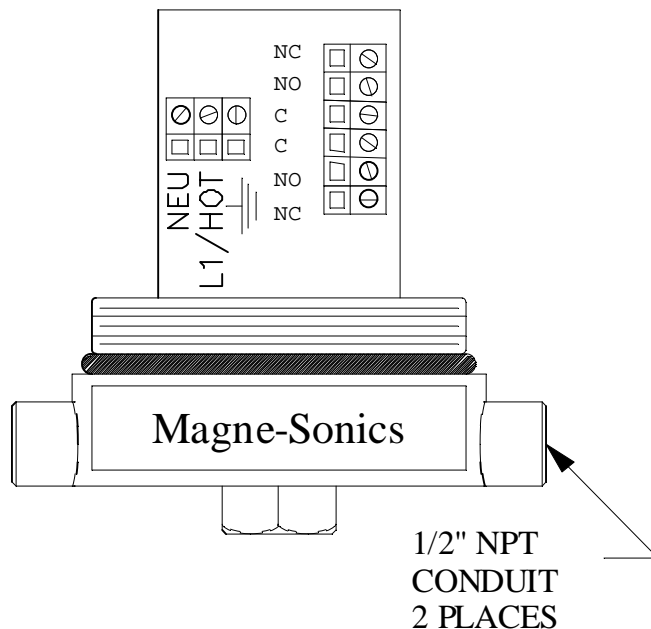

### 3.4 Line Power

Power requirements may be 115 VAC or 230 VAC depending on the model selected. Check to make sure which voltage is correct for the unit being installed. Connect appropriate power to N, L1/HOT and ground symbol terminals (Figure 2-6) which are fuse protected. Wire size if 12 AWG is recommended for primary power and control circuit wiring. Use wiring practices which conform to local codes (National Electrical Code Handbook in the U.S.A.). Use only the standard three wire connection for AC wiring. The ground terminal grounds the instrument which is mandatory for safe operation.

**WARNING!: APPROVED SEAL FITTINGS MUST BE USED IN THE CONDUIT OPENINGS TO PRESERVE THE EXPLOSION PROOF RATING. UNUSED CONDUIT OPENINGS MUST BE SEALED USING A SOLID PIPE PLUG.**

# PART THREE - OPERATION

## SECTION 1 - OPERATING CONTROLS

All operating controls and setup adjustments are clearly marked and accessed by unscrewing the top cover from the enclosure casting. Use the small plastic screwdriver provided to make control adjustments. Do not force any adjustment past its stop to avoid breakage.

### 1.1 Input Select

#### 1. INPUT switch

GRD - Selects grounded input. For use when level sensing element is integrally mounted to the Series 110 (electrode is connected to electronic chassis PROBE terminal automatically via banana plug). The vessel wall is the ground side of the input.

ISO - Selects isolated input. For use when level sensing element is remotely mounted to Series 110 due to excessive temperature, vibration or when unit has differential option (two probe input). The circuit is isolated from ground at the vessel to prevent a dual ground loop.

### 1.2 Sensitivity Select

#### 2. SENS switch

LO - Selects low sensitivity mode (relay trips when resistance between level element and metal vessel wall or ground electrode falls below 100,000 ohms).

HI - Selects high sensitivity mode (relay trips when resistance between level element and metal vessel wall or ground electrode falls below 1 megohm).

### 1.3 High Level

#### 3. HIGH LEVEL indicator (red LED)

Lights whenever the level rises above the level sensing element regardless of the fail safe relay mode selected.

Figure 3-1 Control Panel Layout

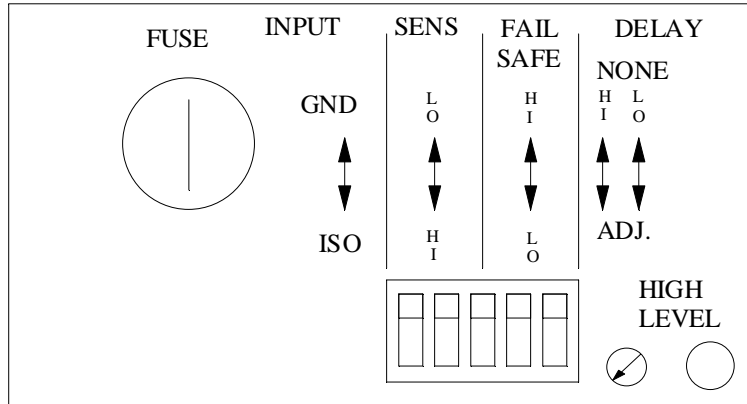

**1.4 Fail Safe  
Relay Operation**

**4. FAIL SAFE switch**

**HIGH** - Selects relay to be energized when the level is not contacting the level element tip. The relay de-energizes when the level contacts the tip of the element.

***Note!:** In the event of power failure or most component failures, the relay would naturally be in the de-energized state. The system, therefore, fails safely. For additional safety, the control contacts of the relay*  
**LOW** - Selects relay to be energized when the level is contacting the level element tip. The relay de-energizes when the level falls below the tip of the element.

**1.5 Relay Time  
Delay**

**5. HI and LO DELAY switches**

These switches, in conjunction with the **DELAY ADJ.** control (item 6), may be used to provide relay time delay to prevent contact chattering or sporadic operation in turbulent materials.

NONE - Selects relay to operate without time delay.

ADJ. - Selects relay to operate with a time delay. With **HI DELAY** switch in this position, relay action will occur a preset time after level contacts the level element tip. With **LO DELAY** switch in this position, relay action will occur a preset time after level falls below the level element tip. With both switches set to **ADJ.** position, delay will occur both on rising and falling level. The delay (0-20 seconds), preset with the **DELAY ADJ.** control, is the same for both delay modes.

6. **DELAY ADJ.** control

Adjusts relay time from 0 to 20 seconds when **HI DELAY** and/or **LO DELAY** switch is in **ADJ.** position.

**1.6 Miscellaneous**

7. **FUSE** (1/4 amp)

Twist cap type fuse is properly rated for the instrument. It should be replaced only with a fuse of the same rating.

***Note!:** The fuse does not protect the relay output control wiring. These circuits and the primary power should be connected through adequately rated circuit breakers.*

## SECTION 2 - INITIAL SETUP

### 2.1 High or Low Alarm/Control

1. Disconnect relay outputs to prevent actuation of final control elements.

**WARNING!: IN HAZARDOUS AREA LOCATIONS, IT IS NECESSARY TO OBTAIN PLANT SAFETY DEPARTMENT APPROVAL BEFORE OPENING THE ENCLOSURE CASING WHILE CIRCUITS ARE POWERED.**

2. Place the following controls and switches to these settings:

<u>Control</u>	<u>Setting</u>
<b>INPUT</b> switch.....	<b>GND</b> (if integral mounted) or <b>ISO</b> (if remote mounted)
<b>SENS</b> switch.....	<b>LO</b> (for very conductive materials - probe to ground resistance less than 100,00 ohms when material touches level element tip) or <b>HI</b> (when probe to ground resistance is from 100,00 ohms to 1 megohm)

*Note!:* When in doubt, use "HI" setting.

**FAIL SAFE** switch..... **HIGH** or **LOW**  
**HI DELAY** switch..... **NONE**  
**LO DELAY** switch..... **NONE**  
**DELAY ADJ.** control..... Fully counterclockwise

3. If relay time delay is desired, place appropriate **DELAY** switch to **ADJ.** position and turn **DELAY ADJ.** control clockwise to increase delay time. Refer to Section 1.5 for details.
4. Reconnect control or alarm device to relay outputs and replace cover on Series 110.

5. Apply power. Test operation by manually bringing level up to the probe tip and observing relay actuation and time delay (if used). If material level cannot be raised up to the probe tip, the tip may be shorted to the vessel wall (or ground electrode) via a wire momentarily connecting them.

*Note!:* The red **HIGH LEVEL** indicator should light when level reaches probe tip, regardless of the fail safe relay mode selected.

## 2.2 Push-To-Test Option

This option is used for verifying high level (overflow) alarm operation only and is not available on units equipped with the differential adjustment option.

Actuate the instrument's **TEST** button or remote "test" switch when the level is known to be below the level sensing element tip and verify correct operation of the instrument and alarm or shutoff device.

# PART FOUR - PRINCIPLE OF OPERATION

See Figure 4-1 for a simplified schematic diagram pertaining to these descriptions:

1. The power supply section (not shown) converts AC line power to appropriate DC voltages for circuit operation. In addition, it supplies a transformer isolated low voltage AC signal for probe excitation.
2. In the DETECTOR section, the low voltage AC signal is applied to the probe and, through a sense resistor, to the vessel wall (COMMON terminal). When material is present between the probe and vessel wall, current flows and a voltage is developed across the sense resistor. A SENS switch selects the value of the sense resistor to provide high or low sensitivity. The voltage across the sense resistor is presented to a high gain amplifier. The output of this amplifier is a sine wave whose voltage is proportional to the conductance between the probe and vessel wall.

The low voltage AC signal is also applied to a pair of inverting comparators to produce two square waves, one in

phase and the other 180° out of phase with the measuring signal. These square waves control analog switches which, together with a differential amplifier, form a phase detector. This circuit allows the Series 110 to measure conductance between the PROBE and COMMON terminals while ignoring capacitance. As a result, The Series 110 is able to provide a very sensitive conductance measurement even when connected with long cable runs which could generate large capacitance values.

The output of the phase detector is filtered to produce a DC voltage proportional to probe conductance. This voltage is applied to an inverting Schmitt trigger which provides a positive on-off action. This forms the output of the detector section and is low on high level.

3. The TIME DELAY section uses the detector section output to charge a capacitor through a variable resistor. This resistor determines the rate at which the capacitor charges or discharges. The voltage on this capacitor is fed to an inverting Schmitt trigger to produce an output signal which is high on high level. Selector switches and diodes allow instant charge or discharge of the capacitor to provide Instantaneous action on high or low level.
4. The time delay section output is fed to the FAIL SAFE selection section. The amplifier in this section acts as a buffer or an inverter depending upon the state of the fail safe switch. When the switch is closed, the unit is in high fail safe mode. The amplifier acts as an inverter whose output is low on high level. When the switch is open, the unit is in low fail safe mode. In this case, the amplifier acts as a buffer so that the output is high on high level.
5. The OUTPUT section consists of a DPDT control relay and a transistor drive circuit. A high level to the transistor from the fail safe selection section energizes the relay.

- The optional PUSH-TO-TEST section (not shown) uses a relay to connect a resistor in parallel with the probe when the TEST push-button is pressed or when a remote switch is actuated. In high level alarm applications, this can be used to simulate a high level condition to verify proper instrument operation.

Figure 4-1 Instrument Operations Schematic Diagram

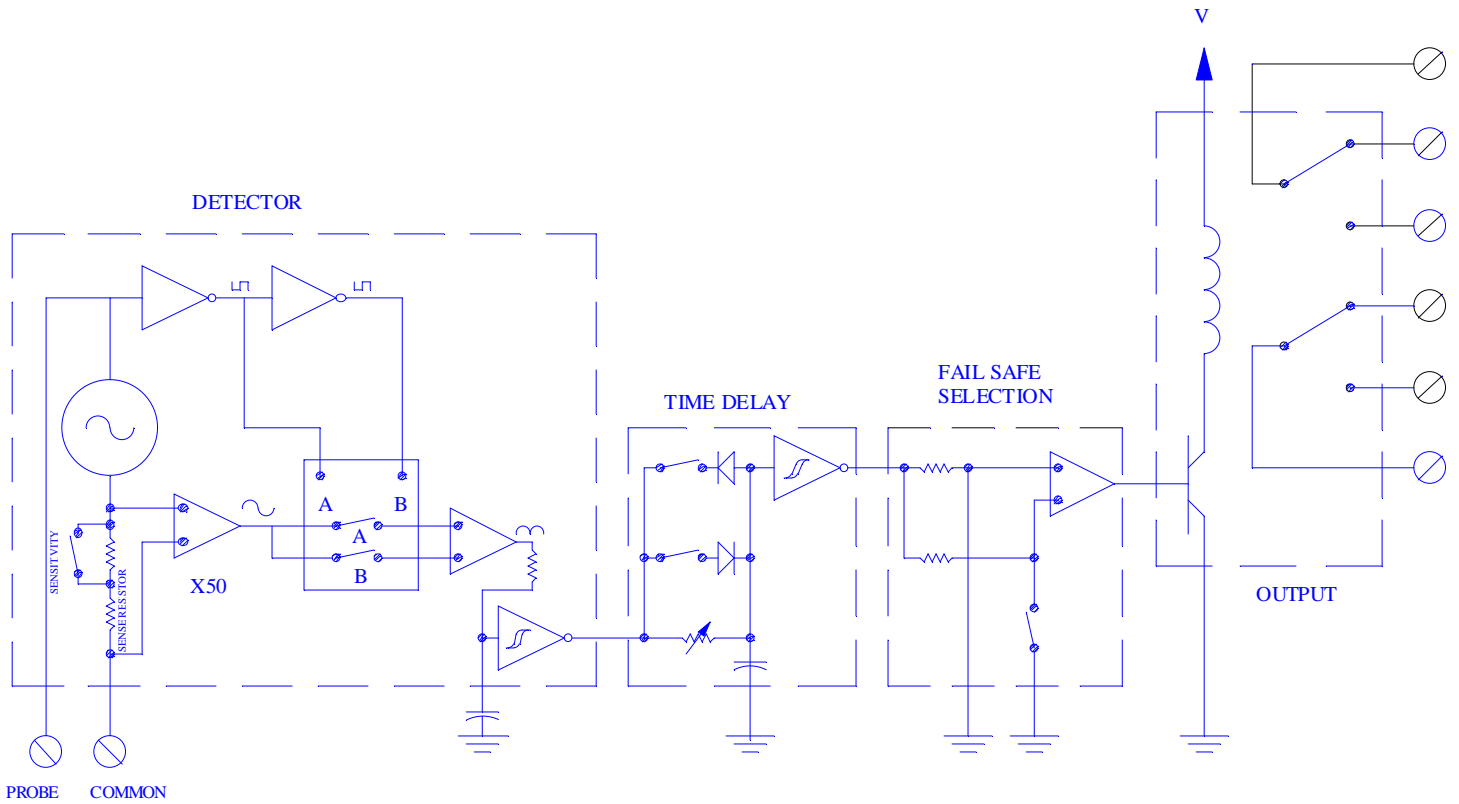

## **PART FIVE - SERVICE AND MAINTENANCE**

### **SECTION 1 - GENERAL**

The electronic chassis assembly is held into the enclosure with two screws in the bottom of the chassis. These are accessible from the sides of the chassis.

Replacement of circuit board components should be performed by a qualified technician. Otherwise, return the entire chassis assembly to the factory after obtaining a return authorization. If possible, include a brief description of the trouble symptoms.

In some applications it may be necessary to clean the probe periodically.

### **SECTION 2 - CUSTOMER ASSISTANCE**

Should service, parts or assistance in troubleshooting or repair be required, please contact your Magne-Sonic representative or the Magne-Sonic Customer Service Department:

**Magne-Sonic Corporation**  
**9441 W. Sam Houston Pkwy Suite 100**  
**Houston, Texas 77099**

**tel: (713) 785-4400**  
**fax: (713) 785-1826**

When ordering spare or replacement electronic chassis assemblies, be sure to use the **complete** assembly part number.

A description of the malfunction as well as the proper return address should accompany all electronic chassis assemblies returned for repair, freight prepaid. All chassis assemblies out of warranty should be accompanied by a purchase order to cover the costs of repair.

*Note!: If the instrument or chassis assembly is damaged during return shipment as a result of inadequate packaging, the customer assumes responsibility for repair costs. It is recommended to use the original shipping carton or an equivalent. Also, Magne-Sonic will not accept instruments returned for repair or replacement unless they are thoroughly cleaned and all process material is removed.*

**PART SIX - SPARE PARTS & ACCESSORIES**

	<u>Description</u>	<u>Part Number</u>
<b>Parts for Remote Mounting</b>	Threaded Adapter .....	1000-3071
	Explosion Proof J- Box..... (with jack & terminal strip)	1000-3072
	Interconnect Cable* (twisted pair).....	99X1W0980
	*Cable has stripped and tinned wires at each end. Specify length up to 1000 feet.	
<b>Miscellaneous</b>	Fuse, 1/4 amp slo-blow.....	99X1F1036
	Relay, 5A contacts, 12 VDC Coil.....	99X2T1026
<b>Electronic Chassis Assemblies</b>	115 VAC - No Options.....	12-1012-101
	115 VAC - Differential Option.....	12-1012-201
	115 VAC - Push-To-Test Option .....	12-1012-301
	230 VAC - No Options.....	12-1012-102
	230 VAC - Differential Option.....	12-1012-202
	230 VAC - Push-To-Test Option .....	12-1012-302