

The Clark-Reliance Corporation

TWIP System

Installation and Maintenance Instructions

- Form E112 -

Table of Contents

A.	Installation	Page 2
B.	Interwiring Control Unit Options	Page 3
C.	Operation	Page 4
D.	Maintenance	Page 5
E.	Trouble Shooting	Page 6
F.	Electrical Specifications	Page 6

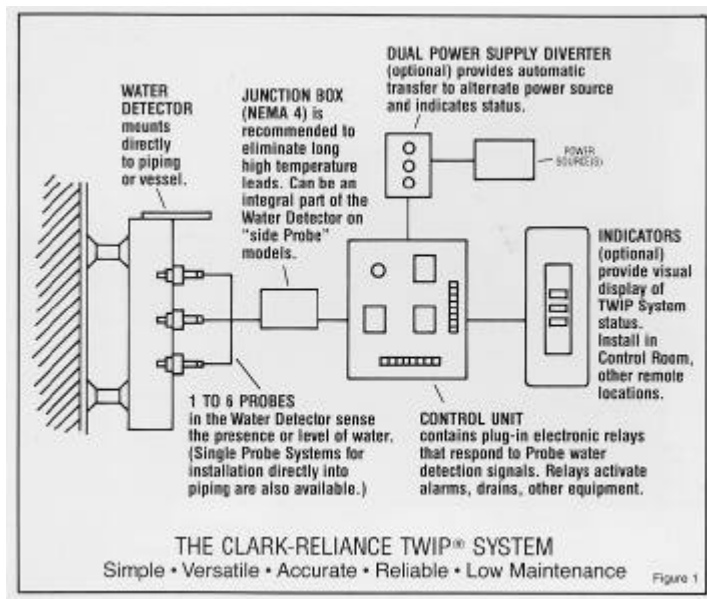

The Clark-Reliance Corporation
16633 Foltz Industrial Parkway
Strongsville, OH 44149
USA

Telephone: (440) 572-1500 FAX: (440) 238-8828

CLARK-RELIANCE TWIP SYSTEM INSTALLATION AND MAINTENANCE INSTRUCTIONS

A. Installation

1. The TWIP Column Assembly should be installed on any cold return line, heater, or other vessel to detect water level. The distance between the TWIP Column Assembly and the application connections should be kept to a minimum. Isolation (Shut-off) valves should be installed to permit maintenance while the vessel is pressurized. A drain valve should be installed on the TWIP Column Assembly. The standard drain connection on the TWIP Column Assembly is 1/2" female socket-weld. The standard vessel connections are 1" male pipe projections. Flanged, butt weld, or female socket weld connections may have been furnished, if specified.

We suggest that all piping between the vessel and the TWIP Column be insulated. Insulation will reduce the effects of cooling and will provide added personnel protection from hot piping. The TWIP Column Assembly may be insulated by field personnel, or with a removable custom-fit Flexpak insulation jacket, when specified. The Flexpak insulation jacket can be specified with the original order, or ordered for an existing system. When ordering, specify the serial number of the existing TWIP Column Assembly. This information is located on the nameplates which are attached to the probe housing and the relay control unit. The serial number will enable Clark-Reliance personnel to assist with technical questions or to identify components. Flexpak jackets are designed for easy removal or installation with Velcro seams.

2. The Control Unit is typically furnished in a NEMA 1 (indoor) or NEMA 4 (outdoor) enclosure. Standard ECIL or R***L model Control Units may be mounted up to 1000 feet away from the TWIP Column. The Control Unit should be mounted in an area that is accessible for inspection and below 140° F. The size of the Control Unit enclosure may vary with customer-selected options. Control Unit dimensions are shown on the drawings provided with the system.

3. The optional Remote Indicator should be mounted in the control room. There is no practical distance limitation between the Control Unit and the Remote Indicator. Although all Remote Indicators are designed for panel mounting, wall mounting brackets are available. Weatherproof enclosures should be specified for outdoor installations. Indicators may be wired in parallel, for multiple indicator installations.

4. Field Wiring from the Control Unit to the Remote Indicator(s) and to the TWIP Column Assembly should be performed as illustrated on the field wiring diagrams. Wiring diagrams are furnished with each TWIP system. The TWIP Column Assembly has been furnished with 30" lengths of high temperature leads exiting from the conduit connection. Longer leads may have been furnished, if requested.

The specifications for the high temperature probe wires are as follows:

<u>Pressure</u>	<u>Wire Specifications</u>
Pressures up to 1000 PSIG	18 GA. Stranded Teflon insulated conductors rated at 300 VAC and 200°C (Belden #83029, Alpha #5857, or equal)
Pressures between 1001 to 3000 PSIG	18 GA. Stranded Teflon-treated glass braided rated at 300 VAC and 400°C, Nickel coated copper conductor U.L. #5182 (Radix #MGT-4503, or equal)

The high temperature probe wires should be routed to a junction box (furnished by C-R, when specified). Low temperature multi-conductor cable may be routed from the junction box to the control unit. The number of required conductors is equal to the number of probes, plus one, for the common connection. For example a four probe TWIP Column Assembly would require 5 conductors. We suggest the following cable specifications: 18 GA. multi-conductor (Tinned Copper), PVC insulated, rated at 300 VAC and 60° C (Belden #8468 or equal).

The same type of wire may be used between the Control Unit and the Remote Indicator(s). The number of conductors required for a Remote Indicator is equal to the total number lights, plus one, for a common conductor. For example, an MTI-4B Remote Bicolor Indicator has 4 red lights, 4 green lights, and one common. Therefore, 9 conductors are required. Refer to the remote indicator field wiring diagram furnished with the system for clarification.

A. Interwiring Control Unit Options

1. Auxiliary Alarm Contacts:

ECIL Control Units that are furnished with auxiliary alarm contacts will provide a dry Form C switch. This switch is rated at 5 Amp @ 120/240 V.A.C. or 1 Amp @ 120 V.D.C., 5 Amp @ 30 V.D.C.

The switches have been provided for all levels, as standard. Refer to the Control Unit wiring diagram for additional details.

2. Test Switch Circuits:

Optional Test Switch Circuits are specified to enable operators / users to test indicator lights and all relay circuits. The push button is furnished in a weather resistant enclosure for convenient mounting. 18 Ga. wire is sufficient for test switch interwiring.

Refer to actual wiring diagrams for more details.

Note: During the test mode, all alarm circuits that are intended to detect water will energize.

3. Dual Power Supply:

Systems furnished with model PSD-120 or PSD-240 Power Supply Diverter are designed to accept two independent power supplies. The primary supply (A) will power the entire system under normal operating conditions. In the event of a power failure, the PSD diverts the power to the secondary supply (B), and continues to power the system. When supply A is restored, the PSD automatically switches back to supply A. A typical installation is illustrated in Fig. 1.

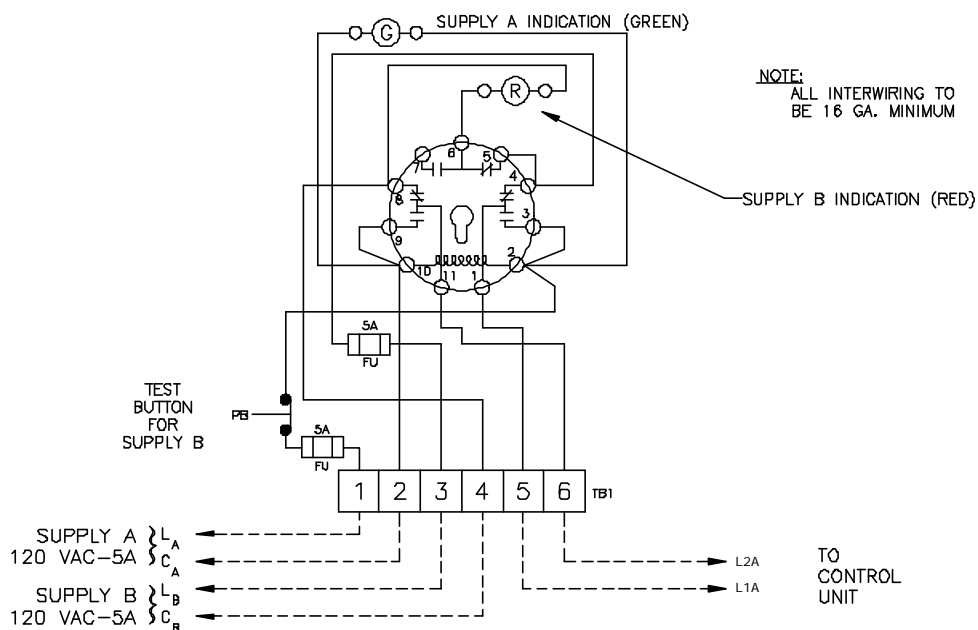

Fig. 1 - Power Supply Diverter Interwiring (PSD-120 shown)

C. Operation

1. Initial operation of all installations:
 - i. Verify all interwiring

- ii. Initial warm-up of the TWIP Column should be done gradually. To do this, keep the water valve closed, open the drain valve widely, and crack open the steam valve for a few minutes. Then, close the drain valve, and slowly open the steam and water valves fully. Check for any leakage near the probes.
- iii. Hot-torquing is recommended on all installations. After initial warm-up, the TWIP Column should be isolated and the drain valve opened. Then, retorque T, V, or ZG probes to 40 Ft - Lb., and FG probes to 90 Ft - Lb. The hot torquing procedure will extend the life of the sealing gasket.
- iv. Close drain valve, and open isolation valves to put the system into service
- v. Turn power on to the control unit.

D. Maintenance

1. Blowdown of the TWIP Column should be performed only as needed, to minimize maintenance. We suggest blowdown to be conducted weekly or monthly, based upon water quality. Blow-down is performed correctly by closing the water valve and slowly opening the drain valve for approximately 15-30 seconds. A brief blow-down is sufficient. Excessive blow-down may shorten the life of the probes.

2. Probe Replacements:

- i. When replacing probes, lubricate threads with a high - temperature lubricant such as Molykote-G, Fel-Pro C or Never Seize.
- ii. Torque T, V, & ZG probes to 40 Ft - Lb. Torque FG probes to 90 Ft - Lb.
- iii. Always install a new sealing gasket, as indicated below, when replacing probes:

<u>Probe</u>	<u>Gasket Part No.</u>
T	WCM-13
V	X175500 (Formerly E10-10)
ZG	E10-10S
FG	E10-10S

Each replacement probe is supplied with 4 gaskets.

- iv. Control Units require no maintenance. However, test switches may be activated at any time.
- v. Indicators that are of the sub-miniature model contain integral L.E.D.'s, and require no replacement parts. Miniature models contain either red L.E.D.'s (Part No. MI-52) or Red/Green L.E.D.'s (Part No. MI-51)

E. Trouble - Shooting Guide

<u>Symptom</u>	<u>Probable Cause</u>	<u>Corrective Action</u>
1. Indicator Light illuminated above level, or remains on during blowdown	1. Failed/Short-circuited probe	1. Remove probe and clean if contaminated, or replace if leakage is detected.
2. Indicator light out at any level	2. B) On models with L.E.D. indicators, problem is either failed relay or wiring problem.	B) Exchange relays and verify if problem moves with relay. Verify all wiring connections, at the probes, and at Control Unit terminal blocks.

F. Electrical Specifications

- i.) RELAY - Standard ECIL and R***L model control units are furnished with Part No. ECID - 23R electronic control relays.

Specifications

Design:	Solid State components enclosed in a clear Lexan, (or polycarbonate) plug-in style housing.
Contact Design:	DPDT (2 form C): two normally open (N.O.) and two normally closed (N.C.) One set is usually occupied by the 24 V.A.C. indicator circuitry. The other set is available for alarm use.
Contact Ratings:	5A @ 120, 240 V.A.C., 5A. @ 30 V.D.C., and 1A. @ 120 V.D.C.
Contact Life:	Mechanical - 5 million operations. Electrical - 100,000 operations min. at full load.
Supply Voltage:	Standard units are designed for 120 V.A.C. supply. Some custom units are fabricated for 220 V.A.C. (Refer to wiring diagram provided for details).
Supply Current:	4.4 VA
Probe Circuit Current:	1.5 mA @ 12 V.A.C. per probe.
Sensitivity:	50,000 Ohms
Temperature Rating:	-40 to +150°F (-40 to +66° C.)
Listing:	Factory Mutual #2N2A4.AF, CSA # LR14001, and

U.L. listed

Direct Mode Operation: When the water rises in the TWIP Column Ass'y. to the probe, (Standard System) the control energizes (LED will be lit). The control remains energized until the water level recedes below the probe. Then, the relay will de-energize (LED will not be lit.).

Direct Mode Operation: With no water level in the TWIP Column Assembly control will be energized (L.E.D. will be lit). As water level rises to contact each probe, the relay will de-energize (L.E.D. will go out). Inverse mode relays are often specified for applications that will detect a normal water level, and are located in geographic areas with frequent power interruptions. During momentary power interruptions, relays corresponding to probes immersed in water will remain de-energized, and no false alarm will occur.

Consult the factory or your local Clark-Reliance Representative with any questions. Technical questions can be promptly answered, if the caller provides the system serial number (Example TD - _ _ _ _ _) or the drawing numbers.

Clark-Reliance Corp.
16633 Foltz Industrial Parkway
Strongsville, OH 44149
Tel: 440-572-1500
Fax: 440-238-8828



Notice to Plant Operators

The use of non-Original Equipment Manufacturer parts (such as glass, gaskets, probes, modules, etc.) will void the Agency Approval (FM, UL, CSA, CRN, ABS, etc.), pressure/temperature rating, and warranty of this equipment. Clark-Reliance requires the use of OEM parts for all repairs on this product in order to maintain plant and personnel safety, and reliable operation.

"PARTS-PLUS"
Critical spare parts for overnight
delivery, direct from the manufacturer.

clark-reliance.com/parts



Steel Valve Repair Kit



Replacement Probes



Gage Glass Repair Kit



Simpliport Module



Simpliport Packing Nut



Replacement Relays

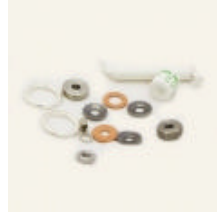

Probe Repair Kit



Replacement EA100 Ass'y



Replacement Micro-switch



Bronze Valve Repair Kit



Valve Packing



Replacement Floats

16633 Foltz Parkway Strongsville, OH 44149 USA
Phone (440) 572-1500 Fax (440) 238-8828
sales@clark-reliance.com www.clark-reliance.com