

NON-BOILER DRUM APPLICATIONS LEVEL SWITCHES & INDICATORS

VERSATILE & EXPERIENCED...

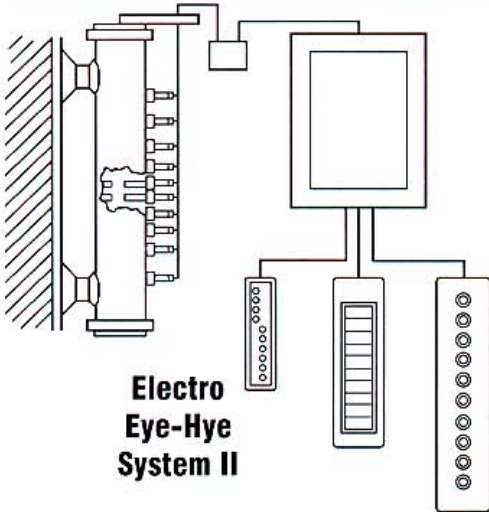

- *Deaerators*
- *Heaters*
- *Condensate Tanks*
- *Drain Pots*
- *Drip Legs*
- *Condensers*
- *Hot Wells*



Magnicator II

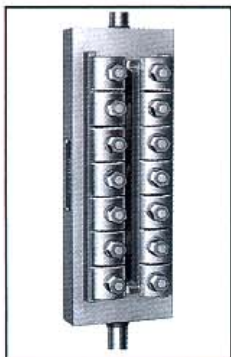

**Flat Glass
(Transparent)
Water Gages**

When your application requires reliable indication or switch point actuation for alarm levels, consult your local Clark-Reliance Corporation Representative.

Over 100 years of level gaging experience.



**EA 100
Float Activated
Levelarms**



**EA 101
Probe Activated
Levelarms**

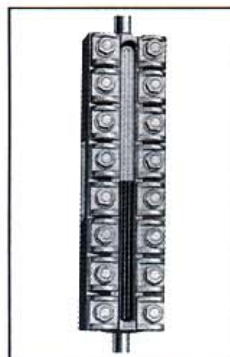

**Prismatic
(Reflex)
Water Gages**

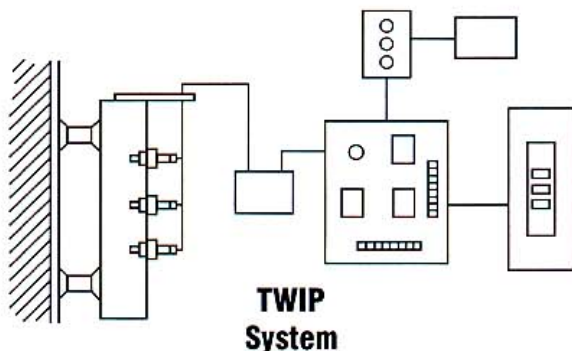

WE STAND BEHIND ALL OUR PRODUCTS...

Safety

When reviewing your particular application, consider the requirement for visual indication or electrical switch points.

Your application may require 4-20 mA signal transmission, a Magnicator or Electro Eye-Hye System may be your solution.

Safe operation requires dependable level indication and control. Clark-Reliance Corporation is your single source for a wide variety of applications.

Conventional time tested drum level equipment offers many options for "Off-The-Drum" applications.

Quality

Clark-Reliance Corporation is ISO 9001 certified to provide you with confidence in design and manufacturing.

All welding is performed by ASME qualified welders.

Reliability

Over 100 years of field experience. Clark-Reliance Corporation (including the Jerguson Level Gage Division), have the largest installed base of these product technologies.

About Your Application

The following will help us to identify your particular application needs.

1. The design pressure of your application.
2. Local viewing of level.
3. Number and location of alarm or critical levels.
4. Vessel connection type and locations.
5. The design temperature.

**OUR REPRESENTATIVES ARE FACTORY TRAINED
TO PROVIDE YOU WITH QUALIFIED ASSISTANCE.**

**OUR SALES TEAM WELCOMES THE OPPORTUNITY
TO ASSIST WITH YOUR LEVEL NEEDS.**

*For additional information,
contact your local Clark-Reliance
representative*

Clark-Reliance®

16633 FOLTZ INDUSTRIAL PARKWAY • STRONGSVILLE, OHIO 44136-5597 • USA
TELEPHONE: (440) 572-1500 • FACSIMILE: (440) 238-8828 • www.clark-reliance.com



NOTE: Clark-Reliance shall not be liable for damages of any kind resulting in part from failure to install its products in accordance with all applicable codes and/or state and local regulations, improper application and/or maintenance.