

# ANDERSON™ SEPARATOR CO.

DIVISION OF

THE CLARK • RELIANCE® CORP.

16633 FOLTZ INDUSTRIAL PKWY.

STRONGSVILLE, OHIO 44136 U.S.A. (440)-572-1500

# MODEL AFS

HORIZONTAL FILTER SEPARATOR

Section: A400

Bulletin: A400.15

Date: 03/16/96

Supersedes: NEW

DRAWN: DEP

CHECKED: KES

SCALE: NONE

DATE: 03/16/96

FILE NO.: A400-15.DWG

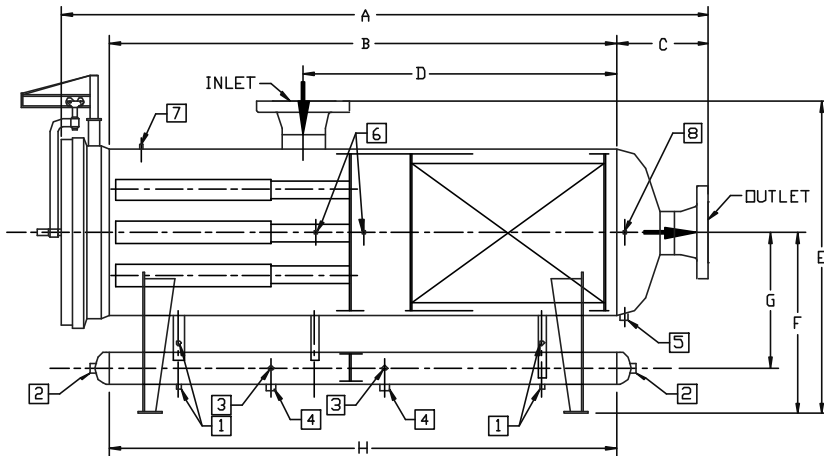

- \* FULL OPENING CLOSURE
- \* LONG STYLE VANE
- \* BARREL SUMP

### HOW TO SPECIFY

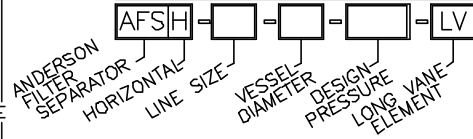

STANDARD MATERIALS	
HEADS	SA-516-70
SHELL	SA-106-B/C / SA-516-70
FLANGES	SA-105
FITTINGS	SA-105
PIPE	SA-106-B/C
SUPPORTS	SA-36 / SA-285
CLOSURE	CARBON STEEL

MODEL AFS-	VESSEL DIAMETER	SUMP DIAMETER	INLET/OUTLET	A(4)	B	C(4)	D	E(4)	F	G	H
2-6	6-5/8" OD	6-5/8	2"	78	62	10	21	43	34	19	62
2-8	8-5/8" OD	6-5/8	2"	86	68	10	27	45	35	20	68
3-10	10-3/4" OD	6-5/8	3"	96	76	11	35	47	36	21	76
4-12	12-3/4" OD	6-5/8	4"	105	84	11	41	49	37	22	84
4-14	14" OD	6-5/8	4"	110	87	12	45	51	38	22	87
6-16	16" OD	6-5/8	6"	124	96	14	53	55	39	23	96
6-18	18" OD	8-5/8	6"	130	102	15	59	59	42	25	102
8-20	20" OD	8-5/8	8"	139	114	15	66	61	43	26	114
8-24	24" OD	10-3/4	8"	157	126	16	78	67	47	29	126
10-26	26" ID	10-3/4	10"	167	132	17	86	69	48	30	132
10-28	28" ID	10-3/4	10"	173	138	17	92	71	49	31	138
12-30	30" ID	10-3/4	12"	183	144	18	99	73	50	32	144
12-32	32" ID	10-3/4	12"	201	168	18	117	75	51	33	168
14-34	34" ID	12-3/4	14"	212	174	19	125	79	54	35	174
16-36	36" ID	12-3/4	16"	221	186	19	132	81	55	36	186
16-42	42" ID	14	16"	251	204	21	150	88	59	40	204
18-48	48" ID	14	18	268	222	24	170	96	62	43	222
20-54	54" ID	16	20"	306	246	26	189	104	67	47	246
24-60	60" ID	16	24"	334	270	27	210	110	70	50	270
24-66	66" ID	18	24"	333	264	29	204	118	75	54	264
24-72	72" ID	18	24"	350	276	30	219	124	78	57	276

**NOTES:**

- 1.) DESIGNED, FABRICATED AND STAMPED IN ACCORDANCE WITH ASME CODE SECTION VIII, DIVISION I.
- 2.) SEPARATION VANES AVAILABLE IN CARBON STEEL, 304-L & 316-L STAINLESS STEEL, OPTIONAL ALLOYS UPON REQUEST.
- 3.) SPECIAL MATERIALS, CONFIGURATIONS, AND HIGHER DESIGN PRESSURES AVAILABLE UPON REQUEST.
- 4.) ADD VALUES IN TABLE 1 TO DIM'S A, C, & E FOR FLANGE RATINGS HIGHER THAN 150#.
- 5.) FILTER SEPARATORS ALSO AVAILABLE WITH REDUCED CLOSURE AND/OR VERTICAL SUMPS
- 6.) DIMENSIONS ARE IN INCHES
- 7.) DIMENSION ARE NOT TO BE USED FOR CONTRUCTION

TABLE 1 (SEE NOTE 4)

NOZZLE SIZE	ANSI B16.5 FLG		
	300#	600#	900#
2"	0	2	2
3"	1	3	3
4"	2	4	4
6"	2	6	6
8"	1	4	6
10"	2	6	8
12"	3	5	7
14"	4	9	10
16"	4	10	10
18"	3	8	10
20"	4	9	12
24"	5	11	14

TABLE 2: STANDARD OPENINGS

ITEM	QTY	SIZE	DESCRIPTION
1	4	3/4"	GAGE GLASS
2	2	2"	L.L.C.
3	2	1"	SYPHON DRAINS
4	2	2"	CLEANOUT
5	1	1"	HYDRO DRAIN
6	2	1/2"	DIFF PRESS
7	1	1/2"	PRESS GAGE
B	1	1/2"	INSTRMNT GAS

ALL STANDARD OPENINGS ARE COUPLINGS

A.S.M.E. CODE STAMPS

