

MATERIAL: AS NOTED
 DRAWN: GRD CHECKED: KES
 SCALE: NONE DATE: 03/16/96

ANDERSON SEPARATOR Co.
 DIVISION OF
 THE CLARK RELIANCE CORP.
 16633 FOLTZ INDUSTRIAL PKWY.
 STRONGSVILLE, OHIO 44136 U.S.A. (440)-572-1500

MODEL AVSC
 IN-LINE VANE SEPARATOR
 VANE COALESCER OPTION

Section: A400
 Bulletin: A400.06
 Date: 3/16/96
 Supersedes: NEW

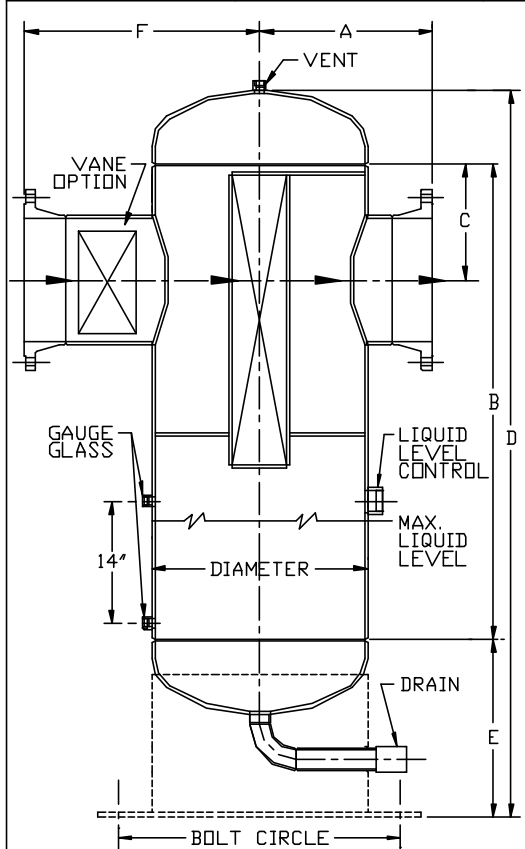

MODEL: AVSC- _____

SIZE		150 LB.	300 LB.	600 LB.	900 LB.	DIMENSIONS NOT FOR CONSTRUCTION						
MODEL AVS-	VESSEL DIAMETER	INLET/OUTLET	A/F	A/F	A/F	A/F	B	C	D	E	BOLT CIRCLE	BOLT HOLES
2-6	6-5/8" OD	2"	9.3 / X	9.3/X	9.3/X	9.3/X	34"	5"	49-1/2"	12"	9-1/8"	4@7/8"
3-8	8-5/8" OD	3"	10.3/X	10.3/X	12.3/X	12.3/X	36"	5"	52-1/2"	12"	11-1/8"	4@7/8"
4-12	12-3/4" OD	4"	12.4/X	14.4/X	14.4/X	14.4/X	42"	8"	65-3/4"	18"	15-1/4"	4@7/8"
6-14	14" OD	6"	15"/X	15"/X	15"/X	15"/X	42"	10"	66"	18"	16-1/2"	4@7/8"
8-16	16" OD	8"	16"/X	15"/X	18"/X	18"/X	42"	10"	66-1/2"	18"	18-1/2"	4@7/8"
10-18	18" OD	10"	17"/X	17"/X	19"/X	19"/X	42"	12"	67"	18"	20-1/2"	4@7/8"
12-20	20" OD	12"	18"/X	18"/X	20"/X	20"/X	48"	12"	73-1/2"	18"	22-1/2"	4@7/8"
14-24	24" OD	14"	20"/X	22"/X	22"/X	22"/X	60"	14"	88-1/2"	20"	26-1/2"	4@7/8"
16-24	24" OD	16"	20"/X	22"/X	22"/X	22"/X	60"	14"	88-1/2"	20"	26-1/2"	4@7/8"
14-30	30" ID	14"	23"/X	25"/X	25"/X	25"/X	72"	18"	102"	20"	32-1/2"	4@7/8"
16-30	30" ID	16"	23"/X	25"/X	25"/X	25"/X	72"	18"	102"	20"	32-1/2"	4@7/8"
16-36	36" ID	16"	26"/X	28"/X	28"/X	28"/X	78"	18"	113-1/2"	24"	38-1/2"	4@7/8"
18-36	36" ID	18"	26"/X	28"/X	30"/X	30"/X	78"	18"	113-1/2"	26"	38-1/2"	4@7/8"
20-42	42" ID	18"	31"/X	31"/X	33"/X	33"/X	84"	20"	125"	28"	44-1/2"	4@7/8"
24-48	48" ID	20"	34"/X	34"/X	36"/X	36"/X	90"	22"	132-1/2"	28"	50-1/2"	8@7/8"
24-54	54" ID	24"	37"/X	37"/X	36"/X	36"/X	90"	24"	134"	28"	56-1/2"	8@7/8"
28-60	60" ID	28"	43"/X	43"/X	44"/X	44"/X	96"	26"	145-1/2"	32"	62-1/2"	8@7/8"
28-66	66" ID	28"	45"/X	45"/X	47"/X	47"/X	96"	28"	145-3/4"	32"	68-1/2"	8@7/8"
30-72	72" ID	30"	50"/X	50"/X	50"/X	50"/X	96"	30"	146	32"	74-1/2"	8@7/8"
30-78	78" ID	30"	55"/X	55"/X	55"/X	55"/X	96"	30"	155-1/2"	36"	80-1/2"	8@7/8"
32-84	84" ID	32"	60"/X	60"/X	60"/X	60"/X	108"	36"	164-1/4"	36"	86-1/2"	8@7/8"
32-90	90" ID	32"	60"/X	60"/X	60"/X	60"/X	108"	36"	164-1/4"	36"	92-1/2"	8@7/8"
36-96	96" ID	36"	60"/X	60"/X	60"/X	60"/X	108"	36"	176"	36"	98-1/2"	8@7/8"

- NOTES:
- DESIGNED, FABRICATED AND STAMPED IN ACCORDANCE WITH ASME CODE SECTION VII, DIVISION I.
 - SEPARATION VANES AVAILABLE IN CARBON STEEL, 304-L & 316-L STAINLESS STEEL, OPTIONAL ALLOYS UPON REQUEST.
 - OPTIONAL SKIRT AND BASE, ANGLE LEGS, OR SUPPORT LUGS AVAILABLE UPON REQUEST.
 - SPECIAL MATERIALS, CONFIGURATIONS, AND HIGHER DESIGN PRESSURES AVAILABLE UPON REQUEST.
 - ABOVE DIMENSIONS NOT FOR CONSTRUCTION.

A.S.M.E. CODE STAMPS

STANDARD MATERIALS

HEADS	SA-516-70
SHELL	SA-106-B/C / SA-516-70
FLANGES	SA-105
FITTINGS	SA-105
PIPE	SA-106-B/C
SUPPORTS	SA-36 / SA-285

HOW TO SPECIFY

AVSC - 16 - 36 - 150 -

MODEL COALESCER OPTION LINE SIZE VESSEL DIAMETER DESIGN PRESSURE NOZZLE CONFIGURATION

AVAILABLE CONNECTIONS

DRAIN: _____ VENT: _____
 SYPHON: _____ L.L.C.: _____
 INSPECTION: _____
 OTHERS: _____

