

CEH Cast Iron Exhaust Heads For Industrial Stacks

Section	A100
Bulletin	A100 80
Date	5/1/98
Supersedes	9/1/96

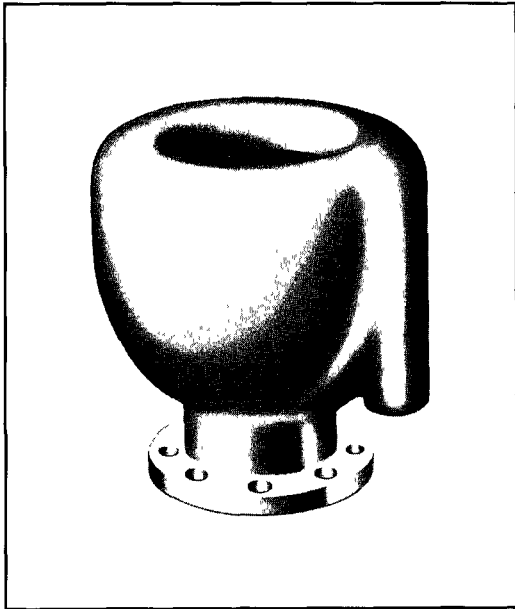

The Anderson Model CEH Exhaust Head is designed for the removal of liquid entrainment such as water and oil from gases and vapors exhausted to the atmosphere. Only clean, dry steam is exhausted. It protects roofs and side walls of buildings. The CEH Exhaust Head has no moving parts or filters. Available with screwed connections in sizes 1½" through 4" and flanged connections in sizes 5" through 12".

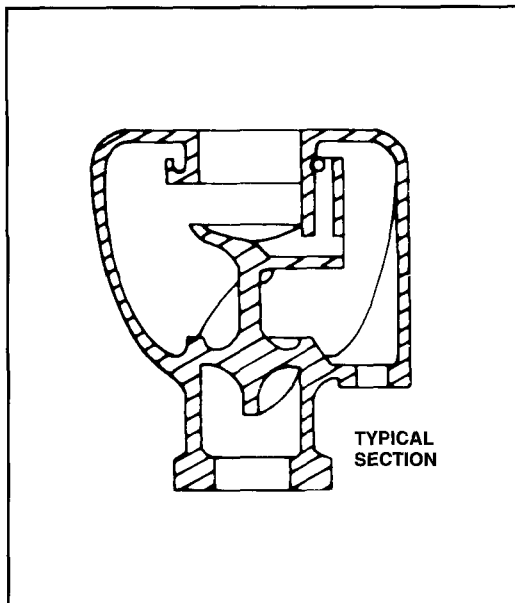

OPERATION – The CEH Exhaust Head uses centrifugal force to separate the entrained liquid. A helix of the proper pitch is inserted in the neck of the Head, and the body is so proportioned that it will collect and discharge oil, grease and water which has been separated from the steam. There is no interruption or slow down of the steam flow – no back pressure. Cast iron construction gives long, trouble-free, non-corrosive service. There are no moving parts and they never require maintenance.

CEH Cast Iron Exhaust Head

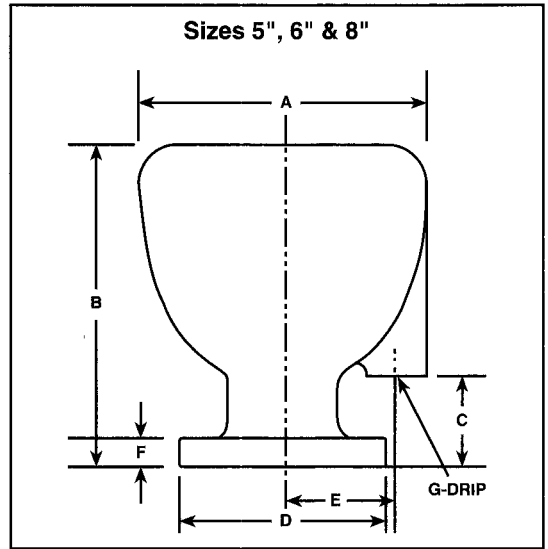
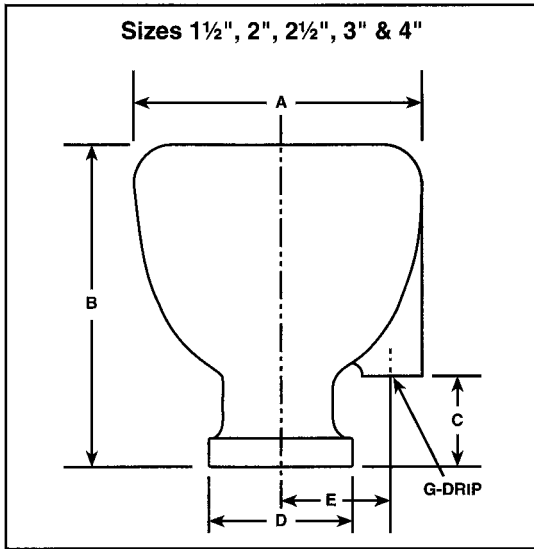

DIMENSIONS IN INCHES

Size	A	B	C	D	E	F	G	Wt. Lbs.
* 1 1/2" - Female NPT	8-5/8"	10"	3-1/4"	4"	3-1/2"	-	3/4" NPT	27
2" - Female NPT	8-5/8"	10"	3-1/4"	4"	3-1/2"	-	3/4" NPT	27
* 2 1/2" - Female NPT	10-3/8"	11"	3-1/2"	5-1/4"	4"	-	1" NPT	40
3" - Female NPT	10-3/8"	11"	3-1/2"	5-1/4"	4"	-	1" NPT	40
4" - Female NPT	12-1/2"	13"	4-3/4"	6-1/4"	4-1/2"	-	1" NPT	60
5" - 125# ASA Flgd	15"	14"	4-3/8"	10"	6-3/8"	1"	1" NPT	110
6" - 125# ASA Flgd	15"	14"	4-3/8"	11"	6-3/8"	1"	1" NPT	115
8" - 125# ASA Flgd	17"	17-3/4"	6-3/8"	13-1/2"	7-3/8"	1"	1-1/4" NPT	200
10" - 125# ASA Flgd	25"	22-1/2"	6"	16"	9-1/2"	1-1/8"	2" NPT	335
12" - 125# ASA Flgd	25"	22-1/2"	6"	19"	9-1/2"	1-1/4"	2" NPT	335

* Bushed From Next Larger Size

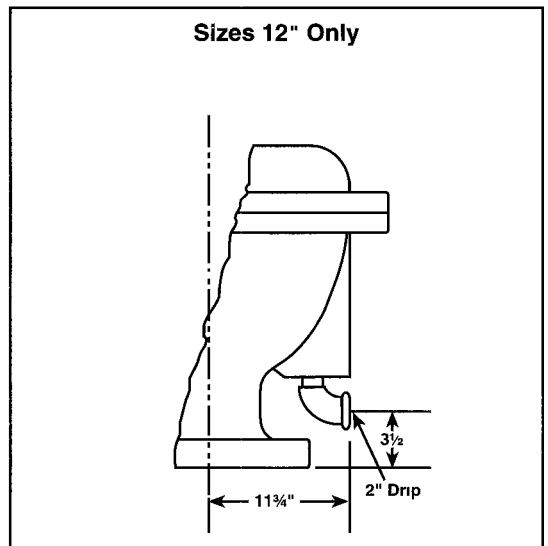
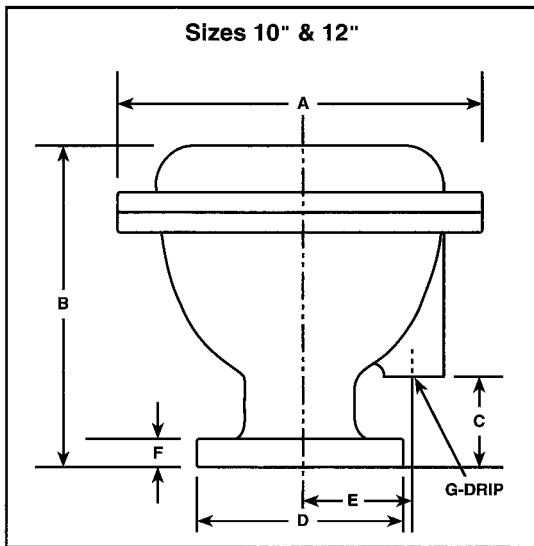

ANDERSON™ SEPARATOR COMPANY

A Division Of The Clark•Reliance Corporation

ASME CODE STAMPS



16633 FOLTZ INDUSTRIAL PARKWAY ■ STRONGSVILLE, OHIO 44136, U.S.A.
PHONE (440) 572-1500 ■ FAX: (440) 238-8828 ■ WWW.CLARK-RELIANCE.COM

