

BILL OF MATERIAL

PIECE NO.	NAME OF PART	QTY.	86V-2-01-A			86V-2-01-T		
			MATERIAL	PART NO.	REMARKS	MATERIAL	PART NO.	REMARKS
1	VALVE BODY	1	STEEL	L-701-A5	ASTM A105	316L SS	L-701-TL1	ASTM A182
2	SEAT	1	416 SS	V-9806-U3	QQ-S-763	316 SS	V-9806-T2	QQ-S-763
3	SEAT GASKET	1	316 SS	P-8378-T		316 SS	P-8378-T	
4	STEM	1	416 SS			316 SS		QQ-S-763
5	SLEEVE-STEM	1	416 SS	S-10328-3-U	QQ-S-763	316 SS	S-10348-3-T	QQ-S-763
6	LOOSE KNOB	1	STELLITE #3			STELLITE #3		
7	YOKE	1	STEEL	L-707-B	S-24093	STEEL	L-316-B	S-24093
8	SLEEVE-INSERT	1	-----	-----		316 SS	V-9830-TL2	
9	PACKING	1	GRAFOIL	G-266		GRAFOIL	G-266	
10	GLAND	1	STEEL	V-18257-9-AL4	S-24093	STEEL	V-18257-9-AL4	S-24093
11	CAP SCREW-GLAND	2	STEEL	P-5729-B71	ASTM A193	STEEL	P-5729-B71	ASTM A193
12	BUSHING	1	ALUM-BR	P-8375-F32	QQ-C-465	ALUM-BR	P-8375-F32	QQ-C-465
13	NUT-BUSHING	1	STEEL	P-5665-A6	ASTM A108	STEEL	P-5665-A6	ASTM A108
14	HANDWHEEL	1	ALUMINUM	V-9808-E	ASTM B26	ALUMINUM	V-9808-E	ASTM B26
15	NUT-STEM	1	STEEL	V-9822-A		STEEL	V-9822-A	
16	SPIRAL GASKET	1	SS/CHLORO.	P-5643-T		SS/CHLORO.	P-5643-T	
17	CAP SCREW-YOKE	4	STEEL	P-6475-B71	ASTM A193	STEEL	P-6475-B71	ASTM A193
18	BALL CHECK	1	440 SS	P-1-I		316 SS	P-1-T2	
19	ROLLPIN	1	STEEL	V-9826-A		316 SS	V-9827-T5	
20	BALL HOLDER BODY	1	STEEL	P-8296-A6	ASTM A108	316 SS	P-8296-T2	QQ-S-763
21	RATING TAG	1	SS	V-18320-2		SS	V-18320-2	

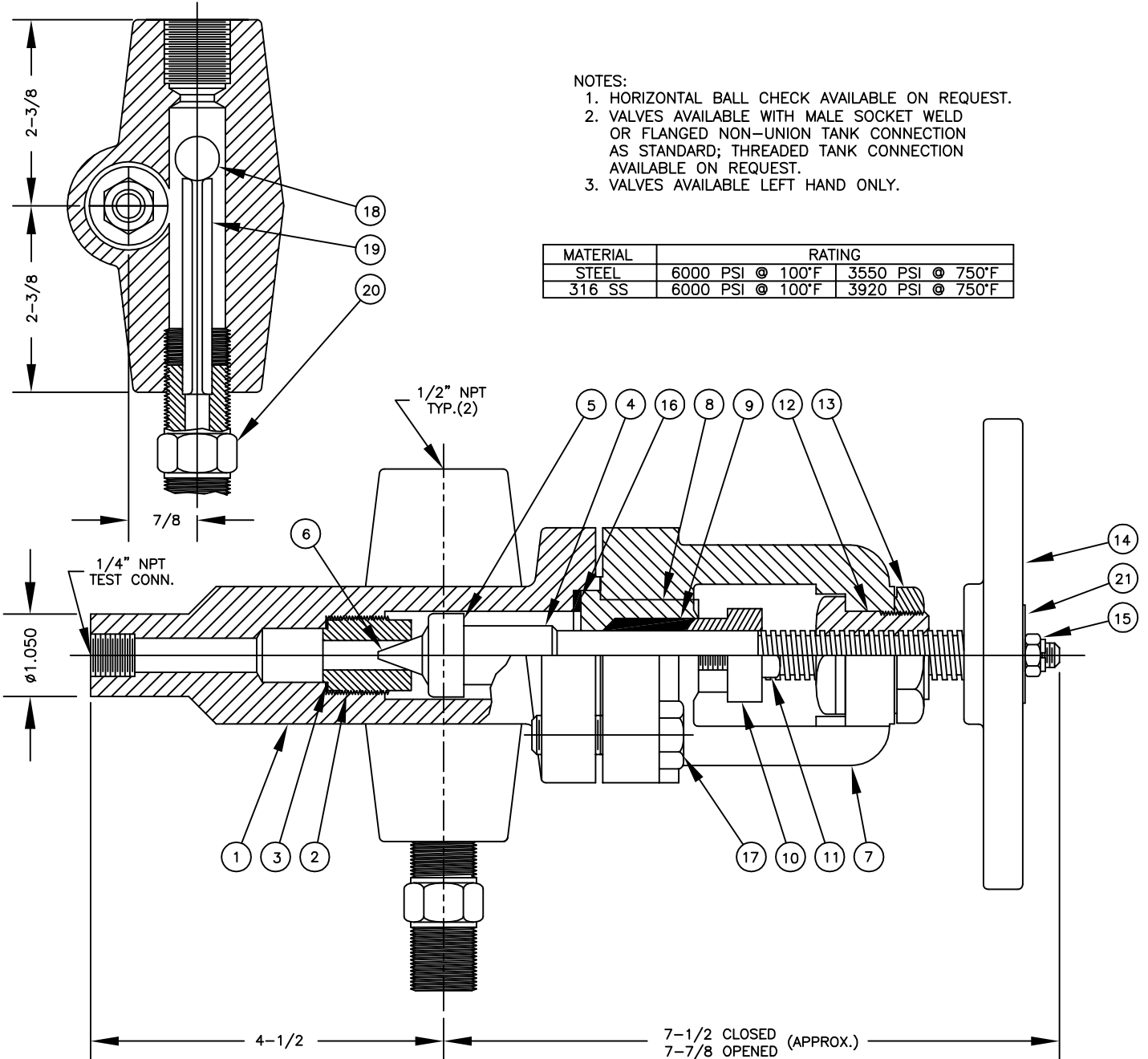

NOTES:

- HORIZONTAL BALL CHECK AVAILABLE ON REQUEST.
- VALVES AVAILABLE WITH MALE SOCKET WELD OR FLANGED NON-UNION TANK CONNECTION AS STANDARD; THREADED TANK CONNECTION AVAILABLE ON REQUEST.
- VALVES AVAILABLE LEFT HAND ONLY.

MATERIAL	RATING	
STEEL	6000 PSI @ 100°F	3550 PSI @ 750°F
316 SS	6000 PSI @ 100°F	3920 PSI @ 750°F

5	REDRAWN & UPDATED	10/16/98	
4	REDRAWN & UPDATED	7/15/96	
3	REDRAWN & UPDATED	3/15/96	
2	REDRAWN & UPDATED	8/27/92	
SYM	REVISION	DATE	APP

**#86V VALVE
NON-UNION TANK CONN.**

**JERGUSON
GAGE & VALVE CO.
STRONGSVILLE, OHIO, U.S.A.**

DRAWN TAP	FILE NO.
CHECKED MJK	DRAWING NO.
APPROVED	86V-2-01
SCALE NONE	DATE 10/16/98
	REV. 5