

BILL OF MATERIAL

PIECE NO.	NAME OF PART	QTY.	77BL-2-02-A			77BL-2-02-T		
			MATERIAL	PART NO.	REMARKS	MATERIAL	PART NO.	REMARKS
1	VALVE BODY	1	STEEL	L-830-A5	ASTM A105	316L SS	L-830-TL1	ASTM A182
2	SEAT	1	416 SS	P-125-U3	QQ-S-763	316 SS	P-125-T2	QQ-S-763
3	STEM	1	416 SS	S-10796-U3		316 SS	S-10796-T2	QQ-S-763
4	YOKE	1	STEEL		ASTM A105	STEEL		ASTM A105
5	WASHER	2	STEEL	S-14062		STEEL	S-14063	
6	SWING BOLT	2	410 SS			410 SS		
7	NUT-YOKE	2	303 SS	V-13464-Q	ASTM A194	303 SS	V-13464-Q	ASTM A194
8	SLEEVE-INSERT	1	-----	-----	-----	316 SS	V-10124-TL2	QQ-S-763
9	PACKING	1	GPH/NICR	G-261		GPH/NICR	G-261	
10	GLAND	1	STEEL	V-9974-A6	ASTM A108	STEEL	V-9974-A6	ASTM A108
11	GLAND FLANGE	1	STEEL	FD-115-A6		STEEL	FD-115-A6	
12	SLEEVE-YOKE	1	303 SS		QQ-S-763	316 SS		QQ-S-763
13	HANDWHEEL	1	MAL. IRON	S-11717		STEEL	S-11717	
14	NUT-STEM	1	STEEL	V-9822-A		STEEL	V-9822-A	
15	SPIRAL GASKET	1	SS/CHLORO.	P-5643-T		316 SS	P-5643-T	
16	CAP SCREW	4	STEEL	P-4393-B71	ASTM A193	SS	P-4393-B71	ASTM A193
17	BALL CHECK	1	440 SS	P-1-I		316 SS	P-1-T2	
18	TAILPIECE, 1/2" FEMALE	1	STEEL	P-198-A6	ASTM A108	316 SS	P-198-T2	ASTM A276
	TAILPIECE, 1/2" MALE			P-400-A6			P-400-T2	
	TAILPIECE, 3/4" MALE			P-120-A6			P-120-T2	
19	NUT-TAILPIECE	1	STEEL	P-70-6-A6	ASTM A108	STEEL	P-70-6-A6	ASTM A108
20	RATING TAG	1	SS	V-8981-77BL		SS	V-18716-77BL	

NOTES:

- TOP & BOTTOM VALVES SAME EXCEPT OPPOSITE HANDING.
TOP VALVE IS 77BL-2-01
BOTTOM VALVE IS 77BL-2-02 (SHOWN)
- FOR INSTRUMENT USE, VALVE IS SUPPLIED WITHOUT HORIZONTAL BALL CHECK & PUSHER PIN STEM. VALVE DESIGNATION IS:
77XL-2-01 TOP VALVE & 77XL-2-02 BOTTOM VALVE.

MATERIAL	ANSI RATING		MFG. RATING	
STEEL	1480 PSI @ 100°F	1010 PSI @ 750°F	3000 PSI @ 100°F	1200 PSI @ 750°F
316 SS	1440 PSI @ 100°F	845 PSI @ 750°F	2100 PSI @ 100°F	850 PSI @ 750°F

STEAM RATING: 750 WSP MAX.

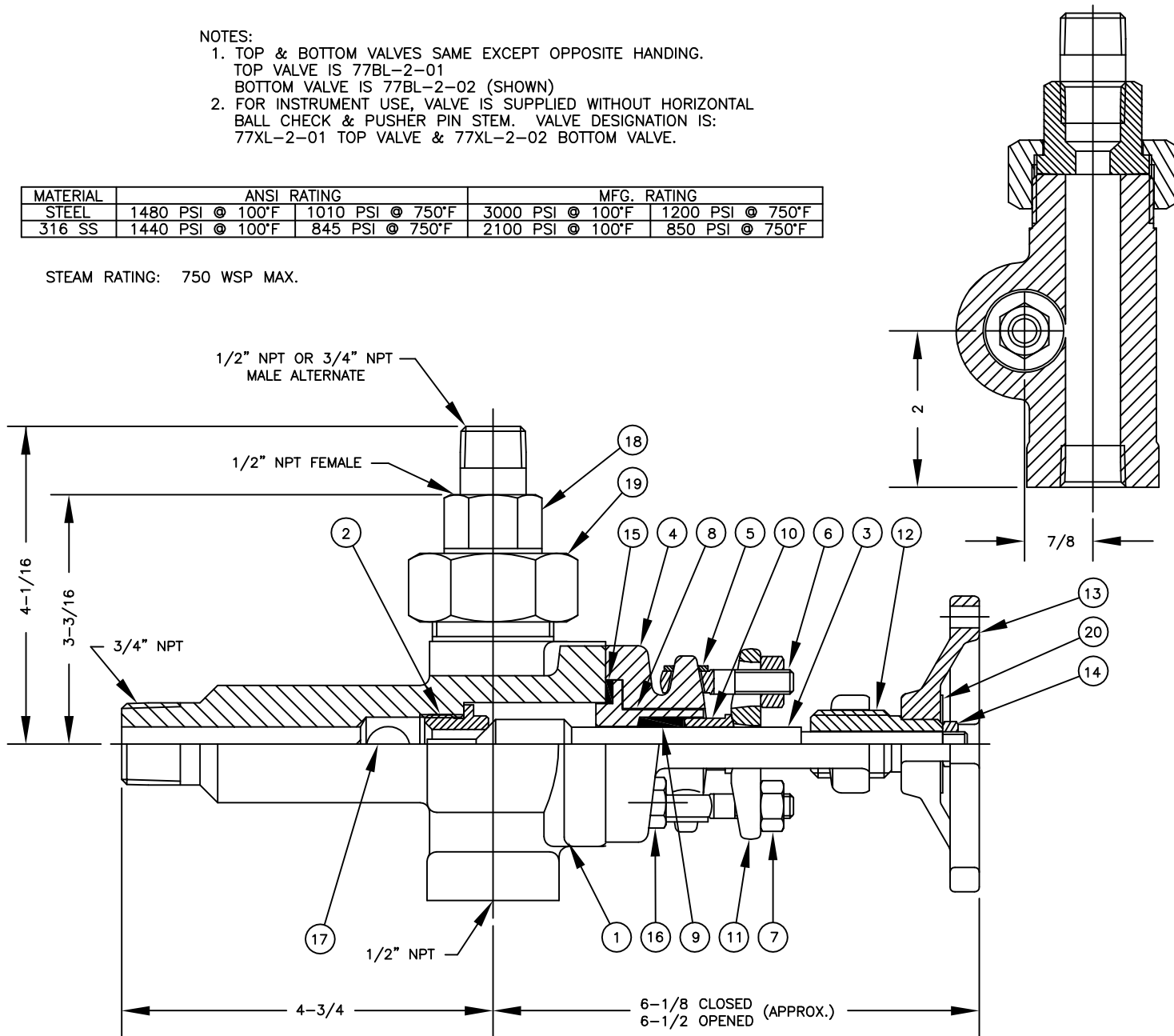

6	REDRAWN & UPDATED	7/7/98	
5	REDRAWN & UPDATED	7/15/96	
4	REDRAWN & UPDATED	3/15/96	
SYM	REVISION	DATE	APP

**#77BL VALVE
NON-UNION TANK CONN.**

**JERGUSON
GAGE & VALVE CO.
STRONGSVILLE, OHIO, U.S.A.**

SCALE NONE DATE 7/7/98

DRAWN TAP	FILE NO.
CHECKED MJK	DRAWING NO.
APPROVED	77BL-2-02
	REV. 6