

BOILER INSPECTION GUIDELINES FOR DRUM LEVEL INSTRUMENTATION

Per Section I of the ASME Code



**Updated to include the 2008 Code Addenda
Effective January 1, 2009**

COURTESY OF



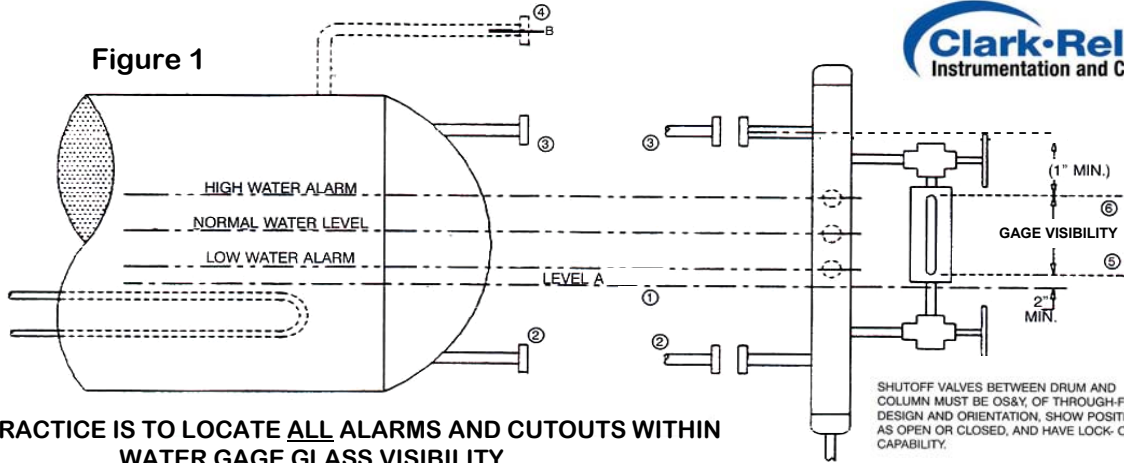

ASME SECTION I WATER GAGE REQUIREMENTS

UNDER 400 PSIG

At Least 1 Direct Reading Gage

400 PSIG and ABOVE

**2 Direct Reading Gages OR
1 Direct Reading Gage and
2 Indirect (Remote) Reading Gages**

Note: When two Indirect Reading Gages are used to meet Section I requirements, the Direct Reading Gage may be valved off, but must be maintained in serviceable condition.

WATER COLUMNS

- 1" NPS minimum vessel connections
- ¾" NPS minimum drain connection
- The steam connection may come out of the top of the vessel (4 on Figure 1))
- The line for the steam connection from the vessel to the water column should be level or slope downward from the drum to the water column (3)
- The line for the water connection from the vessel to the water column should be level or upward from the vessel to the water column (2)
- Water columns are defined as "Standard Pressure Parts" or Standard Welded Parts" in Subsection PG-11. Therefore, a Manufacturers Data report or Code Stamp is not required.
- Water columns are not permitted to be constructed from austenitic stainless steel.

WATER GAGE VALVES

- Minimum ½" NPS connection to the water column
- The Shutoff valves between the drum and the water column must be OS&Y, of through-flow design and orientation.
- Must show position as open or closed, and have lock open capabilities.
- Must have an unrestricted ¼" drain opening.

GAGE GLASS

- Upper visibility to be no higher than lower edge of the steam connection to the drum (6)
- Lower visibility to be no lower than the upper edge of the water connection to the drum (5)
- The lowest visible part of the gage glass (1) must be at least 2" above the lowest permissible water level (Level A)
- Transparent or tubular glass gage glasses that relay on observing the steam-water interface and have multiple sections, must have a minimum of 1" overlap of the visible portions.
- Internal lateral structural supports (webs) in a transparent gage glass that obstruct the viewing of the level are prohibited.
- Ported type water gage glasses must be fitted with proper illumination to provide visual discrimination between water and steam.

Gage Cocks (Try Cocks)

- Not required (Since 1991)
- If used, must be minimum ½" NPS to the vessel.

COURTESY OF



REMOTE LEVEL INDICATOR

- $\frac{3}{4}$ " NPS minimum vessel connections
- When used as a water column, the vessel connections must be 1" NPS minimum.
- $\frac{1}{2}$ " NPS minimum drain connection
- When used as a water column, the drain connection must be $\frac{3}{4}$ " NPS minimum.
- When the two remote level indicators are used at 400 PSIG and above, the remaining gage glass may be shut off, but must be maintained in the serviceable condition.
- The display of the two indirect indicators must be continuously visible in the operators control area.
- Conductivity probe devices, when properly outfitted, meet Section I requirements for Remote Level Indicators. See Figure 2 below.

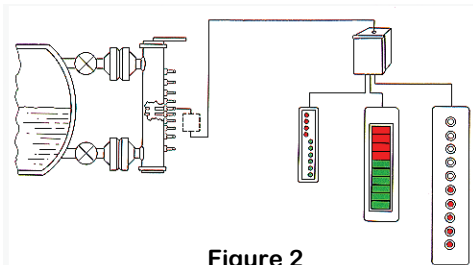

Figure 2

MAGNETIC WATER LEVEL GAGE

- Considered an indirect level indicator because the actual water line can not be viewed
- Does not replace the required direct reading gage glass
- Limited use to 900 PSI
- Switches or accessories for control purposes are prohibited
- Can not be used as a water column for the attachment of water gage glasses or other instruments.
- Indication scale must comply to PG-60 requirements regarding gage glass placement for viewing range.
- $\frac{3}{4}$ " NPS minimum vessel connections
- Can be fitted with a 4-20 mA transmitter for remote transmission.
- Material of construction may include certain types of stainless steel (refer to PG-5.5)
- $\frac{1}{2}$ " NPS minimum drain connections
- Can be fitted with a 4-20 mA transmitter for remote transmission.

COURTESY OF

WATER COLUMN ISOLATION SHUTOFF VALVES

- Y-pattern globe valves are acceptable as long as the lowest edge of the seat is at least 25% of the inside diameter below the centerline of the valve. See Figure 3 below.

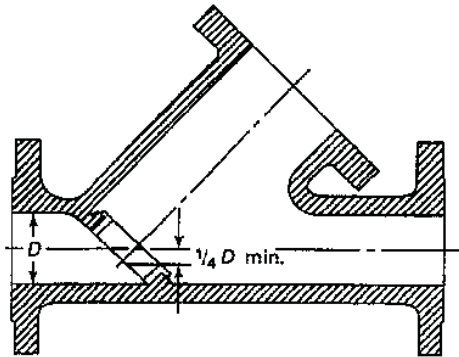

Figure 3

HRSG DESUPERHEATER DRAIN POTS

- Drain pots that are installed to detect and remove unvaporized water shall include automatic detection of water and automatic operation of the drain pot valves. See Figure 4 below.

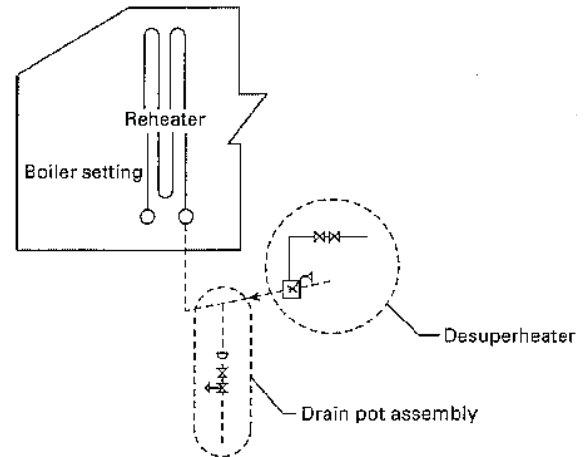

Figure 4

COURTESY OF

COMMON NON-COMPLIANT DRUM LEVEL EQUIPMENT ARRANGEMENTS

- ❑ **Magnetic Gages being used as direct reading gages. Magnetic Gages are permitted as a local indirect gage or as a remote level indicator when used with a 4-20mA transmitter to a control area indicator. The Magnetic gage can not replace the direct reading gage glass.**
- ❑ **When the over 400 PSI Code option arrangement is used (two indicators for the one gage glass), the two indirect indicators must be continuously visible in the operators control area and the gage valves may be isolated. Viewing the boiler level on a plant operation control system computer screen does not qualify as a continuously visible indicator unless it is always on the screen. If keystrokes or mouse clicks are required to view the indirect indicator it does not meet the Code as an indirect indicator.**
- ❑ **When the *over 400 PSI Code Option Arrangement* is used, the existing gage glasses must be able to be brought into service without further action other than opening the isolation valves, closing the drain valve, and turning on illuminators. Gage glasses that can not be turned on without repairs do not meet ASME Code requirements.**
- ❑ **Bi-color ported type water gages must be fitted with proper illumination to provide visual discrimination between water and steam. If not, the gages are not in Code compliance.**
- ❑ **Not having two independent indirect reading gages when the gage glass image is not directly visible in the operators control area or transmitted to the operators control area by means of a camera, fiber optic system, or mirrors.**

RECOMMENDATIONS

The following are not required by ASME Code, but are recommended for safe operation:

1. Chain Operators should always be used to provide a safe means of operating gage glass isolation valves under normal conditions and in the event of glass leakage.
2. A conductivity probe system combined with a 4-20 mA transmitter, or, two conductivity probe systems provide the best reliability due to the redundancy of probe systems. The use of two or three differential pressure transmitters (redundant devices) is not recommended due to the likelihood of simultaneous common mode failure due to environmental variations (especially freeze-up) or loss of device sensing leg primes.
3. Trip and alarm points should fall within the visible range of the gage glass for visual verification.
4. Freeze protection for outdoor applications should be provided to prevent damage to the level instrumentation devices.
5. Transparent gage glass illumination should be provided to give optimum viewing of the drum level, especially in low lit areas and when the transparent gage is elevated above the viewing platform.
6. Exposed piping to the gage glass, especially the upper steam piping, should be insulated to minimize any level density error due to cooling and condensate formation.

COURTESY OF

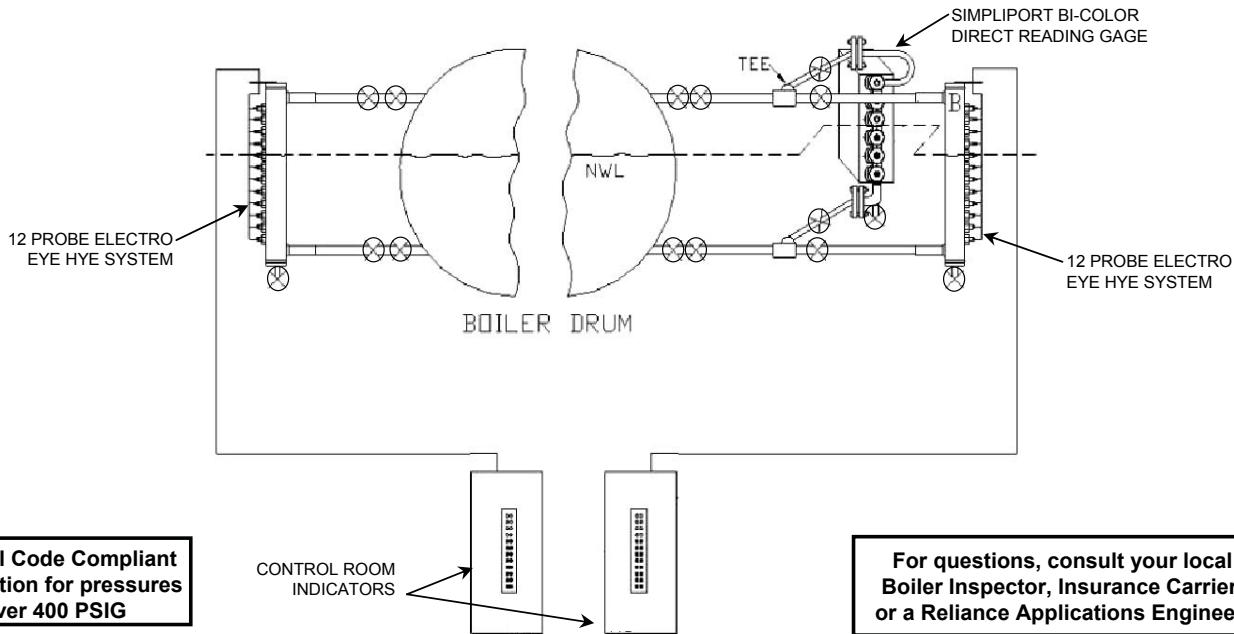

COURTESY OF

Clark-Reliance[®]
Instrumentation and Controls Group

16633 Foltz Parkway • Strongsville, OH USA • Phone: (440) 572-1500 • Fax: (440) 238-8828
 www.clark-reliance.com • sales@clark-reliance.com